

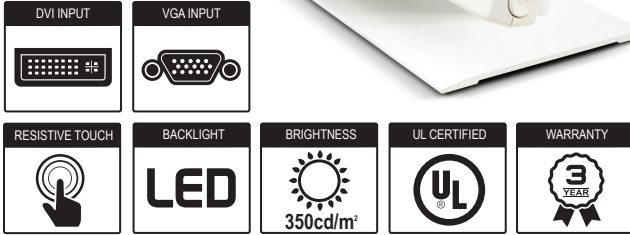

**TAA** **COMPLIANT**



## MA19BH-AB-1690

Gvision's MA19BH is a 19" industrial grade medical monitor designed specifically for use in the medical industry. It's the perfect touch screen solution for healthcare applications such as nursing stations, computer-aided therapy, electronic medical record keeping, paperless charting, patient self-check-in / registration or point-of-information. Gvision's medical monitors are fully certified with UL 60601.

### DIMENSIONS

Unit: Inch

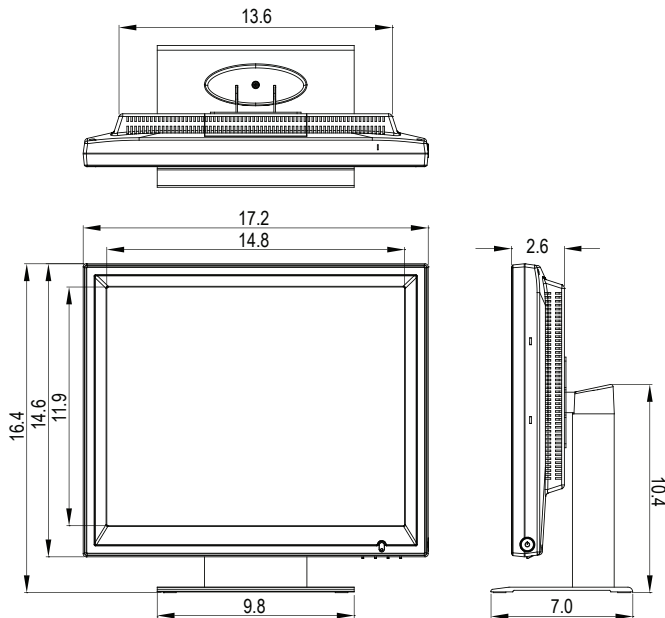

### FEATURES

- 19-Inch Screen Size, 1280 x 1024 Resolution
- 5-Wire Resistive Touch Panel
- RS232 / USB Type-A Touch Interface
- Supporting Inputs: DVI-D / VGA (15-Pin D-Sub)
- 350 nit High Brightness
- LED Direct Backlight Unit
- Integrated Stereo Speakers
- Designed for 24/7 Operation
- **UL60601** Certified
- TAA Compliant
- 3-Year Warranty

### SPECIFICATIONS

MODEL	MA19BH-AB-1690
Screen Size	19 In
Resolution	1280 x 1024
Backlight	LED Direct Backlight
Aspect Ratio	5 : 4
Viewing Angle	170° / 160°
Response Time	5ms
Brightness	350cd/m <sup>2</sup>
Contrast Ratio	1000 : 1
Display Area	376.4 (H) x 301.1 (V)
INTERFACE	
DVI In	1
VGA In	1
Audio	1
USB Type-A / RS232	1 / 1
AUDIO	
Speaker	2 (1W Per Channel)
TOUCH	
Touch Type	Resistive
Touch Panel	5-Wire / 1-Point Touch Resistive
Touch Interface	RS-232 or USB A type
POWER	
Input Voltage	DC12V / 5A
Electrical Rating	AC100~240V, 50~60 Hz
Saving Mode	< 0.5W
TEMPERATURE	
Operating	32° F ~ 104° F (0° C ~ 40° C)
Storage	-4° F ~ 140° F (-20° C ~ 60° C)
Humidity	10% ~ 80%
DIMENSIONS (WxHxD)	
Inch (in)	17.2 x 16.4 x 7
Millimeter (mm)	438.0 x 417.5 x 180.0
WEIGHT	
Net Weight	17.6 lbs (8 kg)
REGULATION	
Certification	FCC / UL60601 / cUL
VESA™	
Mount Size (mm)	100 x 100

Specifications subject to change without any notice