

# **USER'S MANUAL**

**9-WIRE DOT MATRIX PRINTER**

GSX-190



# GSX-190

# User's Manual

## Trademark Acknowledgement

Citizen, Command-Vue, VuePrint: Citizen Systems America Corporation

Epson: Seiko Epson Corporation

IBM, Proprinter: International Business Machines Corporation

Windows: Microsoft Corporation

CITIZEN is a registered trade mark of CITIZEN WATCH CO., LTD., Japan  
CITIZEN es una registrada de CITIZEN WATCH CO., LTD., Japan

Copyright © 2006 by Citizen Systems America Corporation

# Important Safety Instructions

---

Provided by Underwriters Laboratories, Inc.

1. Read all of these instructions and save them for later reference.
2. Follow all warnings and instructions marked on the product.
3. Unplug this product from the wall outlet before cleaning. Do not use liquid or aerosol cleaners. Use a damp cloth for cleaning.
4. Do not use this product near water.
5. Do not place this product on an unstable cart, stand or table. The product may fall, causing serious damage to the product.
6. Slots and openings on the cabinet and the back or bottom are provided for ventilation. To ensure reliable operation of the product and to protect it from overheating, do not block or cover these openings. The openings should never be blocked by placing the product on a bed, sofa, rug or other similar surface. This product should never be placed near or over a radiator or heat register. This product should not be placed in a built-in installation unless proper ventilation is provided.
7. This product should be operated from the type of power source indicated on the marking label. If you are not sure of the type of power available, consult your dealer or local power company.
8. This product is equipped with a 3-wire grounding-type plug, a plug having a third (grounding) pin. This plug will only fit into a grounding-type power outlet. This is a safety feature. If you are unable to insert the plug into the outlet, contact your electrician to replace your obsolete outlet. Do not defeat the safety purpose of the grounding-type plug.
9. Do not allow anything to rest on the power cord. Do not locate this product where the cord will be walked on.
10. If an extension cord is used with this product, make sure that the total of the ampere ratings on the products plugged into the extension cord do not exceed the extension cord ampere rating. Also, make sure that the total of all products plugged into the wall outlet does not exceed 15 amperes.
11. Never push objects of any kind into this product through cabinet slots as they may touch dangerous voltage points or short out parts that could result in a risk of fire or electric shock. Never spill liquid of any kind on the product.
12. Except as explained elsewhere in this manual, don't attempt to service this product yourself. Opening and removing those covers that are marked "Do Not Remove" may expose you to dangerous voltage points or other risks. Refer all servicing on those compartments to service personnel.
13. Unplug this product from the wall outlet and refer servicing to qualified service personnel under the following conditions:
  - A. When the power cord or plug is damaged or frayed.
  - B. If liquid has been spilled into the product.
  - C. If the product has been exposed to rain or water.
  - D. If the product does not operate normally when the operating instructions are followed. Adjust only those controls that are covered by the operating instructions since improper adjustment of other controls may result in damage and will often require extensive work by a qualified technician to restore the product to normal operation.
  - E. If the product has been dropped or the cabinet has been damaged.
  - F. If the product exhibits a distinct change in performance, indicating a need for service.

# Table of Contents

	<b>Introduction . . . . .</b>	<b>v</b>
	GSX-190 Features . . . . .	v
	About this Manual . . . . .	vii
	Service and Support Information . . . . .	viii
<b>Chapter 1</b>	<b>Setup . . . . .</b>	<b>1</b>
	Unpacking and Setting Up the Printer . . .	1
	Installing the Ribbon . . . . .	5
	Connecting to a Power Outlet . . . . .	7
	Connecting Your Computer . . . . .	7
<b>Chapter 2</b>	<b>Command-Vue™ III Control Panel . . .</b>	<b>11</b>
	ON LINE Menu Group . . . . .	13
	FONT 1 Menu Group and FONT 2 Menu Group . . . . .	14
	PITCH Menu Group . . . . .	15
	MODE Menu Group . . . . .	16
	INSTALL Menu Group . . . . .	17
	VuePrint™ Menu Group . . . . .	17
	Other Command-Vue Functions . . . . .	23
<b>Chapter 3</b>	<b>Paper Handling . . . . .</b>	<b>25</b>
	Setting the Paper Thickness Lever . . . . .	25
	Setting the Paper Select Lever . . . . .	27
	Printing on Single Sheets . . . . .	27
	The Tractor Unit . . . . .	29
	Printing on Continuous Paper . . . . .	32
	Paper Tear-Off . . . . .	35
	Paper Parking . . . . .	37
	Printing on Envelopes . . . . .	39
	Printing on Overhead Transparencies . . .	42
	Printing on Multi-part Forms and Labels .	42
	Top-of-Form Fine Adjustment . . . . .	45

---

<b>Chapter 4</b>	<b>Setting Up Commercial Software . . .</b>	<b>49</b>
<b>Appendix A</b>	<b>Option . . . . .</b>	<b>51</b>
	Serial Interface . . . . .	52
<b>Appendix B</b>	<b>Maintenance . . . . .</b>	<b>55</b>
	Cleaning . . . . .	55
	Alarms . . . . .	56
	Troubleshooting . . . . .	58
<b>Appendix C</b>	<b>Specifications . . . . .</b>	<b>65</b>
	Printer Specifications . . . . .	65
	FCC Compliance Statement . . . . .	67
	EMI Compliance Statement . . . . .	67
<b>Appendix D</b>	<b>Command Reference . . . . .</b>	<b>69</b>
	Citizen Commands . . . . .	69
	Epson FX-850 Emulation Commands .	71
	IBM Proprinter III Emulation Commands . . . . .	74
	<b>Index . . . . .</b>	<b>77</b>

# Introduction

Your new Citizen GSX-190 is a high-quality 9-wire printer well suited to the needs of your home or office. The GSX-190 blends sophisticated styling and Near Letter Quality output with versatile paper handling. With Citizen Acoustic Technology (C.A.T.)™, the GSX-190 is among the world's quietest printers. The Command-Vue™ control panel gives you full control of the GSX-190's many powerful features, all in plain English.

## GSX-190 Features

### Compatibility

- ❑ Built-in emulations for both Epson FX-series printers and the IBM Proprinter III plus GSX-unique print features.
- ❑ The ability to define printer settings in a macro lets you easily restore preferred default settings.

### Printing Features

- ❑ Maximum print speed up to 240 CPS in draft and 45 CPS in near letter quality.
- ❑ Citizen Acoustic Technology, (C.A.T.), Citizen's patented noise control technology.
- ❑ Near letter quality fonts in Roman, Sans Serif, Courier, Prestige, Script, and Orator.

- ❑ Standard print features such as expanded, condensed, emphasized, doublestrike, italics, superscripts and subscripts, and reverse white-on-black print.
- ❑ High-resolution graphics (240 dpi × 216 dpi).

## **Command-Vue III™ Control Panel**

- ❑ The Command-Vue III control panel clearly indicates the current state of the printer and menu settings.
- ❑ Control the entire array of printer default settings for functions and features with the VuePrint menu.
- ❑ Change print pitch, and font with easy-access menus available at the press of a key!

## **Paper-handling Flexibility**

- ❑ The GSX-190's paper parking feature lets you quickly switch between continuous paper and single sheets feeding.
- ❑ A top-of-form fine adjustment customizes the first printing position, to suit your forms!
- ❑ The printer automatically advances continuous-feed paper to the tear bar for easy removal.
- ❑ The GSX-190 prints envelopes, multi-copy forms, continuous labels, and thick paper.

## **Standard Interface**

- ❑ Either the Parallel Interface or the USB Interface is available as the factory option.

## Option

- Expand your printer's capabilities with an optional serial interface.

## Easy on the Environment

Citizen, accepting our responsibility to protect the environment, strives to produce earth-friendly printers:

- The cardboard container is made from 75% recycled materials and is 100% recyclable.
- No CFCs (chlorofluorocarbons) are used in the manufacturing of the printer, its components, or the carton. The foam end pads have been replaced with easy-to-recycle cardboard.

## About this Manual

Notes, cautions, and warnings are used like this:

---



Notes contain helpful hints and other important information that help you use your GSX-190 printer better.

---



Cautions provide information about procedures which, if not observed, could result in damage to the GSX-190 or other equipment.

---



Warnings mean failure to follow specific procedures and practices may result in personal injury.

---

In our continuing effort to provide the best products possible, we welcome your suggestions and comments on how we can improve the GSX-190 or its documentation.



## **Service, Support and Supplies**

It is our goal to make your GSX-190 ownership experience a satisfying one. Citizen's support staff is available to respond to your needs for setup, operational and troubleshooting assistance and to arrange for convenient repair service if needed. Refer to the service and support contact information that follows or write us at **Citizen Systems America Corporation**.

### **Technical Support**

For technical information or assistance with setup, operation or troubleshooting your GSX-190 beyond what your dealer can provide, call Citizen's Technical Support Group at (310) 781-1460 Monday through Friday between 8:00 AM and 5:00 PM pacific time or contact us anytime by email at [techsupport@citizen-systems.com](mailto:techsupport@citizen-systems.com) We recommend you visit our website at [WWW.CITIZEN-SYSTEMS.COM](http://WWW.CITIZEN-SYSTEMS.COM) to obtain printer drivers and other technical information as well.

### **Repair Service**

In the U.S.A. and Canada, to verify whether your printer requires service, and to arrange for repairs, call Citizen at (310) 781-1460 Monday through Friday between 8:00 AM and 5:00 PM pacific time. You may also visit our website [WWW.CITIZEN-SYSTEMS.COM](http://WWW.CITIZEN-SYSTEMS.COM) for further information. In Mexico, central and south America, contact the dealer from whom your printer was purchased for referral to the nearest Citizen-Authorized repair center, or contact Citizen Systems America Corporation.

### **Supplies and parts**

Supplies such as ribbons are available through your local Citizen dealer. For added convenience, supplies and service parts for out of warranty requirements may be ordered from Citizen's authorized part and supply distributors. In the U.S.A. and Canada contact Citizen at (310) 781-1460 for the dealer nearest you or you may also visit our website [WWW.CITIZEN-SYSTEMS.COM](http://WWW.CITIZEN-SYSTEMS.COM) In Mexico, central and south America, contact the dealer from whom your printer was purchased.

Information in this document is subject to change without notice.

# Chapter 1

## Setup

Before unpacking your printer any further, take a few moments to consider where you plan to put it.

- ❑ Choose a flat, stable desk or printer stand that also accommodates your paper supply. Be sure there is enough room around the printer to allow the paper to flow easily in and out.
- ❑ If you are using a wooden table, protect the surface from possible damage by placing a mat under the printer.
- ❑ Position the printer so that the power cord and computer cable do not interfere with the paper flow.
- ❑ Avoid sudden, severe changes in temperature and humidity, as well as direct sunlight, dust and grease. Pick a clean area for daily operations.
- ❑ Select a steady source of 120-volt electricity and check for other appliances that may be using the same circuit. Copiers, heaters, air conditioners, and other motorized equipment can cause power fluctuations that may interfere with your printing projects.

## Unpacking and Setting Up the Printer

Unpack the printer, and save all original packing materials. They are specially designed to protect the printer and will make repacking easy if you ever need to ship the printer.



All packing materials (carton, cardboard inserts) are 100% recyclable if you do not plan to save them.

## Carton Contents

In your printer carton you should have received the six items shown in Figure 1-1. If anything is missing, contact your dealer.

Before continuing, remove all packing material from the printer.

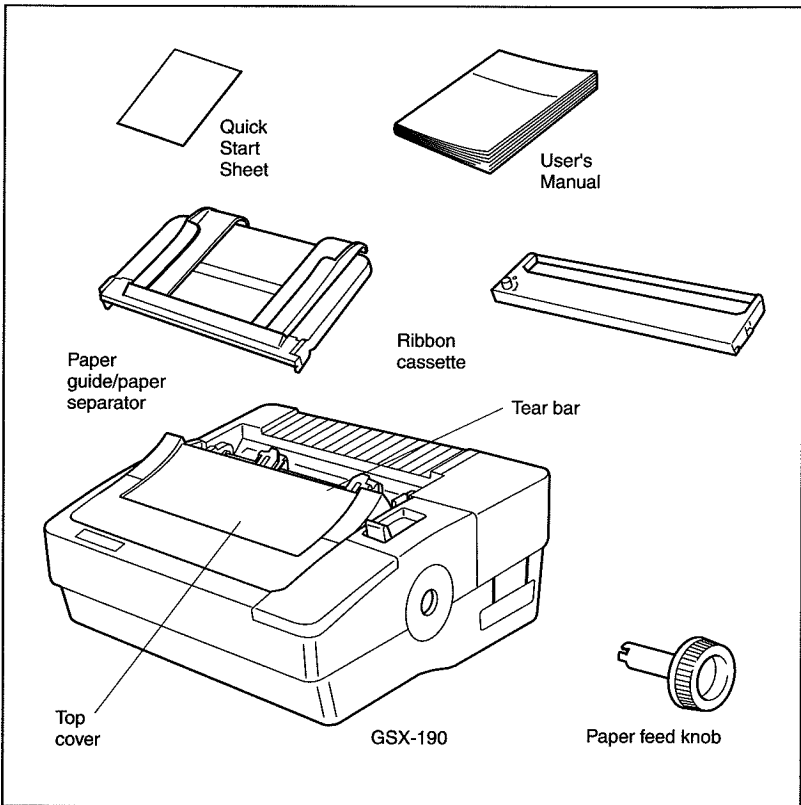

Figure 1-1. With the GSX-190 printer come these additional items: a) User's Manual (this book); b) ribbon cassette; c) paper guide; d) paper feed knob; and e) Quick Start Sheet

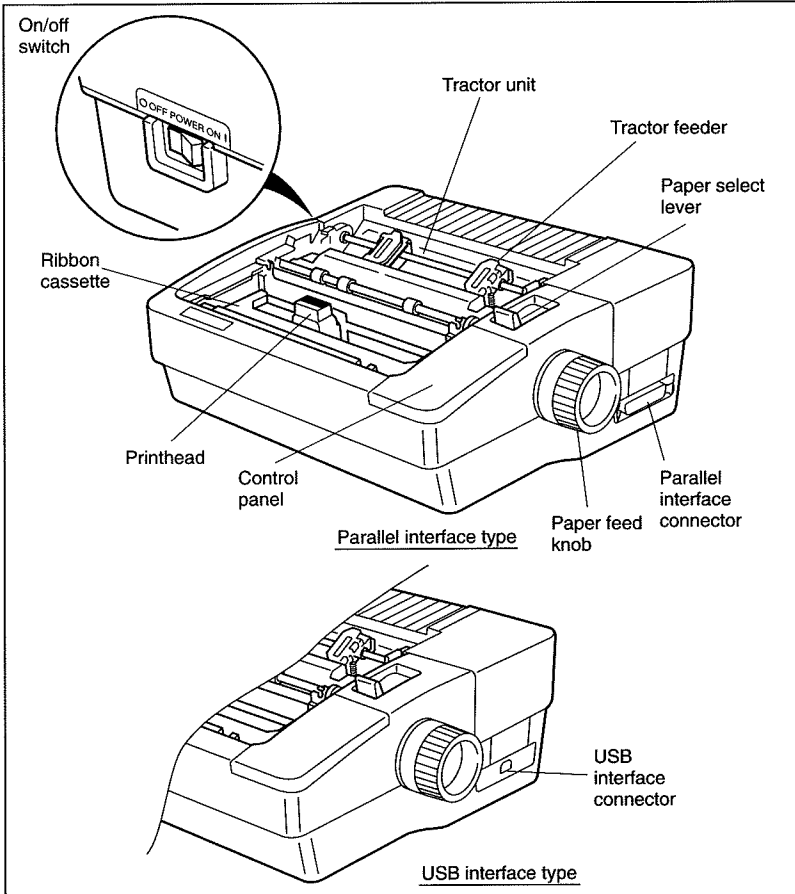

Figure 1-2. Printer components.

## Identifying Printer Components

Figures 1-1 and 1-2 highlight the main components of the GSX-190 printer. Either the Parallel Interface or the USB Interface is installed as the standard interface.

## Installing the Paper Feed Knob

To install the paper feed knob, simply insert the cylinder end of the knob with the four prongs into the knob opening on the printer as shown in Figure 1-3. Push the knob in gently until it engages. Then turn it to ensure that the platen moves.

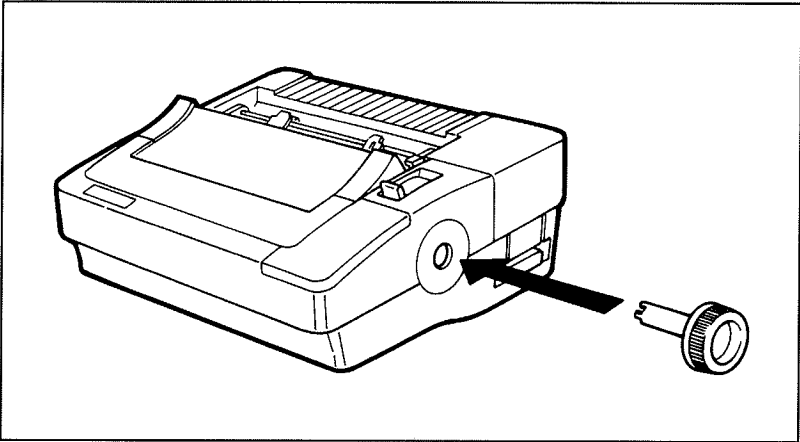

Figure 1-3. Installing the paper feed knob.

## Opening the Top Cover

The top cover is a two-part hinged cover with a tear bar at one edge. You must open it to install and change ribbons, and to make other adjustments to the printer. When you open the cover, you should open it in two stages—first, fold it open at the hinge, and then lift it out. (See Figure 1-4.)

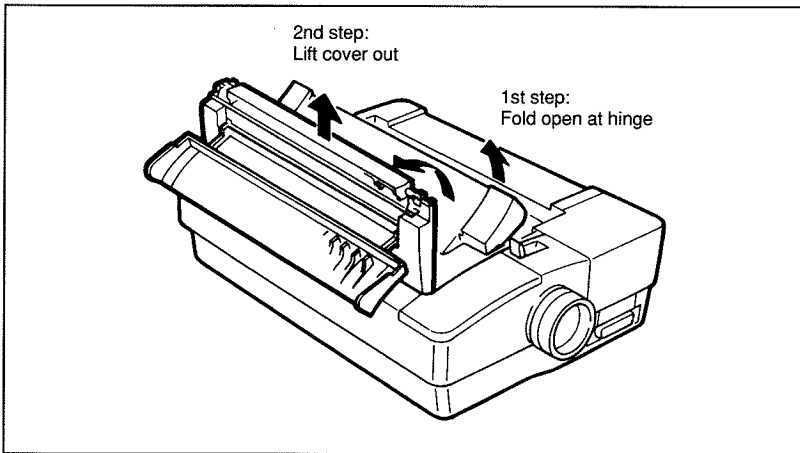

Figure 1-4. Open the top cover in two steps: 1) fold back the cover to the hinge, then 2) lift the cover out.

## Replacing the Top Cover

Installing the top cover is also a two-stage process. Each half of the cover should click into place separately to ensure complete closure.

Begin by holding the cover folded open at the hinge. Grasp it with a hand at each end or with one hand in the middle. Insert the tabs at the front edge of the cover into the two small slots located on the inside lip of the printer opening. Recline the cover into position and press each corner. You can hear the corners click into place.

Then unfold the transparent part of the cover and press it into place.

## Installing the Ribbon

Ribbon installation is a quick procedure but please heed these two precautions:



If you are replacing a ribbon, be sure the printer is off and the printhead has had time to cool.



Carefully follow the instructions for correct ribbon placement. Improper placement can cause smudged printing and may jam the ribbon.

- 
1. Open the top cover, and slide the printhead to the center of the platen for convenience.
  2. Remove the new cassette from the packaging and position it with the ribbon knob aligned over the post protruding from the left end of the floor of the printer opening.
  3. Lower the ribbon cassette into place and snap it down. When properly installed, the ribbon

cassette will not lift out easily; it “snaps” out. See Figure 1-5.

4. Slide the ribbon down into position between the printhead and the metal ribbon mask. This is easy to do! Do not force the ribbon between the ribbon mask and the ribbon guide (the black plate closest to the platen). See Figure 1-5.
5. Turn the knob clockwise, and advance the ribbon until there is no slack.
6. Slide the printhead right and left a few times to be sure that it moves smoothly without snagging the ribbon.
7. If you are installing a ribbon that is not the same type as the ribbon it replaces, be sure to select the correct type with the VuePrint menu or the

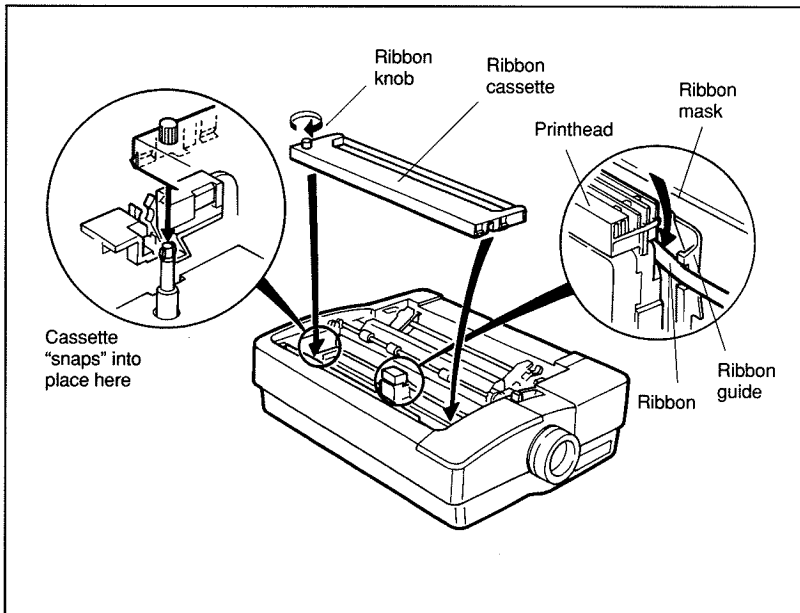

Figure 1-5. Install the ribbon cassette.

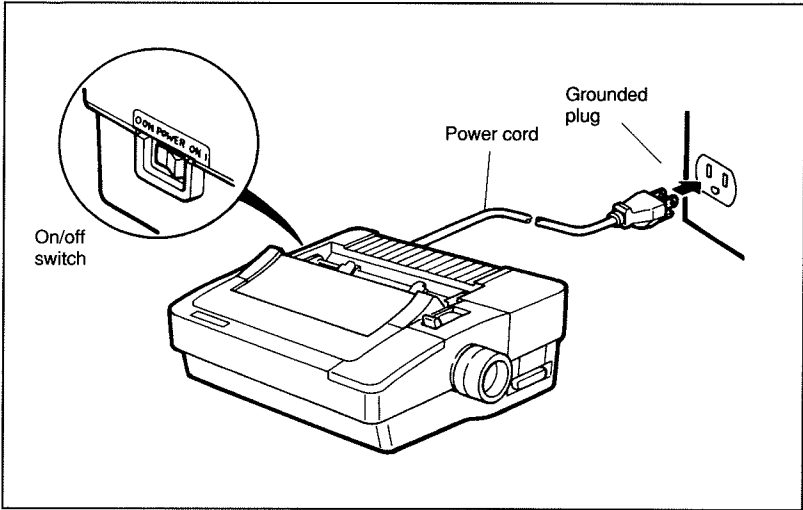

Figure 1-6. Connect the printer to a power outlet.

Command-Vue INSTALL menu. See Chapter 2 for more information on making these settings.

## Connecting to a Power Outlet

First look at the on/off switch and be certain it is off. Plug the cord into a standard 120-volt grounded outlet (see Figure 1-6). It's a good idea to protect your printer with a surge protector.

## Connecting Your Computer

Your GSX-190 printer and your computer communicate through a cable that is readily available at local computer dealers. You will need a Centronics parallel printer cable or a USB printer cable because your new printer has a parallel interface or a USB interface. This connector is standard. The computer connector, however, varies slightly between computers, so be sure to check your computer owner's manual for exact details on the



kind of connector you need on the other end. Nearly all IBM-compatible computers use the same type of connector. Standard parallel printer cables are six feet long. Longer cables may cause problems.

If you have the GSX-190 option serial interface, use the VuePrint menu to select a serial interface protocol.



Before making any connections, turn off both your printer and your computer.

---

Connecting the parallel interface cable to your printer is very simple.

1. Figure 1-7 shows the connector, which is on the right side of your printer, near the rear. Move the small wire latches out of the way and fit the cable connector onto the printer connector. They are designed to fit only one way, so this is a foolproof connection. Be sure the connectors are firmly attached, but do not use a lot of force; it is possible to bend or break the connector pins.

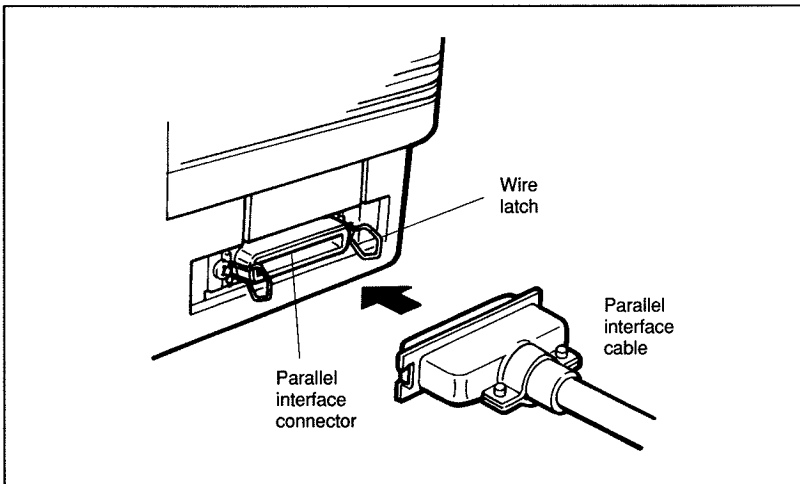

Figure 1-7. Connecting the parallel interface cable.

2. Press the wire latches into place to hold the cable in place.

Connecting the USB interface cable to your Printer is very simple.

Figure 1-8 shows the connector, which is on the right side of your printer, near the rear.

They are designed to fit only one way, so this is a foolproof connection. Be sure the connectors are firmly attached.

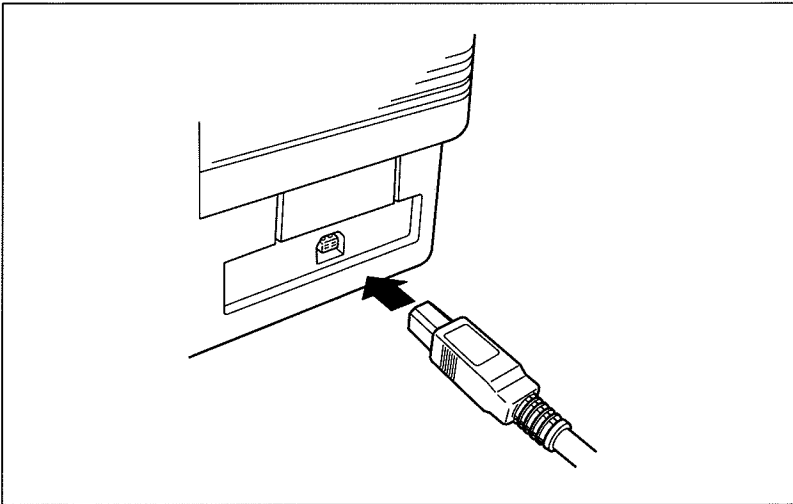

Figure 1-8. Connecting the USB interface cable.

The parallel (or USB) and serial interface can each be connected to a computer if you have more than one computer you want to use with the GSX-190. The interfaces work on a “first come, first served” basis; the interface that receives data first becomes the active interface and remains active until you turn the printer off and on again. When an interface is active, the other one is not used, even if data is sent while connecting the USB interface cable to your Printer is very simple. The active interface is not receiving data.



## Chapter 2

# Command-Vue™ III Control Panel

The Command-Vue III control panel lets you easily control many of the GSX-190's features. To select a particular option, move one of the slide switches until the desired option is displayed in a window. Then activate the option by pressing its corresponding key. The menu light beside the window comes on so you know the option has been selected.

### Slide Switches and Menu Windows

The slide switches are used to select a menu group. By moving the slide switch up or down, you enter a particular menu group and thus change the options displayed in the windows. The control panel has two slide switches: the MENU slide switch (the larger of the two) and the STYLE slide switch.



You can move the STYLE slide switch only when the MENU slide switch is at STYLE. The STYLE slide switch is locked out if the MENU slide switch is at ON LINE, INSTALL or VuePrint.

---

During normal operation, leave the MENU slide switch in the ON LINE position. The ON LINE menu group controls the most frequently used printer functions.

The key to the right of each window selects or cancels the option displayed in the window. The menu light to the left of each window indicates the current state

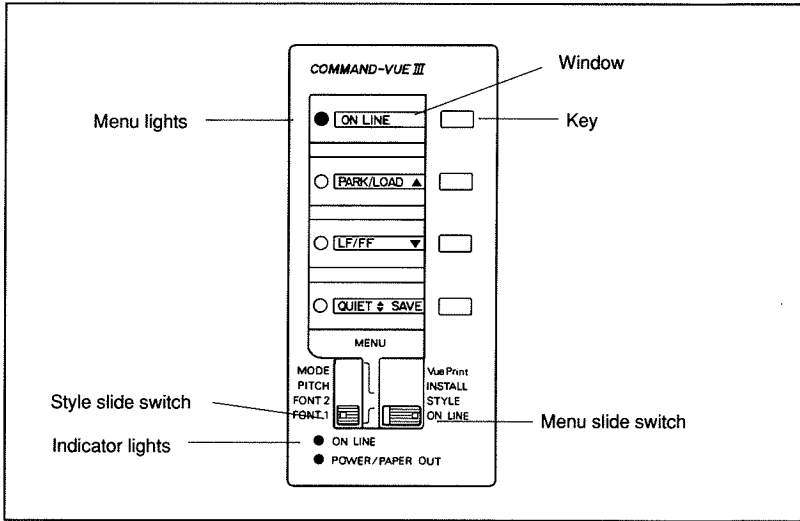

Figure 2-1. Command-Vue III control panel.

of each option. The option displayed in the window is active when its corresponding menu light is on; the option is inactive if the light is off.

In most cases, a key acts like a toggle; pressing the key turns the displayed option on and off. On some menus, pressing the key performs a particular function (like advancing the paper).

Also note that a key may have dual functions. In some menu groups, a key performs one function when the printer is on line but performs another function when the printer is off line. Details of a key's function are explained in each respective menu group later in this chapter.

## Indicator Lights

- ❑ The ON LINE indicator comes on when the printer is on line; it goes out when the printer is off line.

- ❑ The PAPER OUT/POWER indicator comes on when the printer is on and ready for use. This light flashes when the printer is out of paper, or paper is jammed in the printer.

## ON LINE Menu Group

Move the MENU slide switch to ON LINE to enter the ON LINE menu group. This menu group lets you select the paper handling and other functions most frequently used during printing. Table 2-1 shows the functions available in the group.

Table 2-1.  
ON LINE menu group.

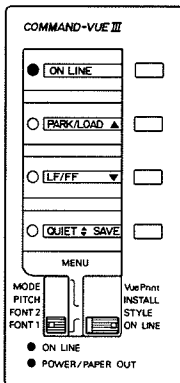

Key	With printer on line	With printer off line
ON LINE	Sets printer off line.	Sets printer on line.
PARK/LOAD	If pressed for more than two seconds, enters top-of-form adjustment mode. See "Top-of-Form Fine Adjustment" in Chapter 3 for more information.	Cycles continuous paper among three positions: parked, at top-of-form, and at tear bar. See "Paper Parking" in Chapter 3 for more information.
LF/FF	If pressed for more than two seconds, enters top-of-form adjustment mode. See "Top-of-Form Fine Adjustment" in Chapter 3 for more information.	Advances paper one line (LF stands for "Line Feed"). If pressed more than two seconds, advances continuous-paper to the tear bar for easy form removal (FF stands for "Form Feed") or it ejects a single sheet from the printer.
QUIET/SAVE	Selects/cancels quiet mode, which reduces noise by printing a line in two passes. Print quality is not affected, but print speed is reduced by half.	If pressed for more than three seconds, clears the print buffer.

## On Line and Off Line Modes

When the printer is “on line”—its normal operating mode—it can receive data from your computer and print. When the printer is “off line,” it stops printing and responds only to control-panel instructions, such as moving the paper.

## Parking Continuous Forms

When you turn on the printer, it brings the continuous paper to the top-of-form position. (This is the first line of printing on a page. See “Top-of-Form Fine Adjustment” in Chapter 3 to change this position.) After you print a document, the printer automatically advances the paper forward to the tear-off position. (The paper is positioned so the perforation is directly beneath the tear bar.)

The PARK/LOAD key lets you manually move the paper from the top-of-form position, to the tear-off position, and to the park position with a mere push of a key. When the printer is off line, each press of the PARK/LOAD key moves the paper to another position. The paper moves—in sequence—from top-of-form, to the tear-off position, to the park position, back to the top-of-form position, and so on.

## FONT 1 Menu Group and FONT 2 Menu Group

When you enter the FONT1 or FONT2 menu groups, you can select one of the eight typefaces shown in Table 2-2. To enter either of these menu groups, move the MENU slide switch to style, and move the STYLE slide switch to FONT 1 or to FONT 2.



You can move the STYLE slide switch only when the MENU slide switch is at STYLE. The STYLE slide switch is locked out if the MENU slide switch is at ON LINE, INSTALL or VuePrint.

Table 2-2.  
FONT 1 and FONT 2  
menu groups.

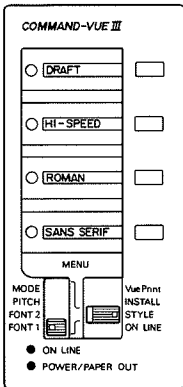

Key	With printer on line or off line
DRAFT	FONT 1: Draft
HI-SPEED	FONT 1: High Speed
ROMAN	FONT 1: Roman
SANS SERIF	FONT 1: Sans Serif
COURIER	FONT 2: Courier
PRESTIGE	FONT 2: Prestige
SCRIPT	FONT 2: Script
ORATOR	FONT 2: Orator

## PITCH Menu Group

The PITCH menu group lets you select the type size in characters per inch (cpi). To enter the PITCH menu group, set the MENU slide switch to STYLE and set the STYLE slide switch to PITCH. See Table 2-3.



Table 2-3.  
PITCH menu group.

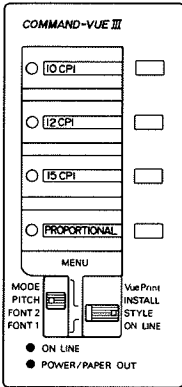

Key	With printer on line or off line
10 CPI	ABCDEFGHIjij 10 CPI
12 CPI	ABCDEFGHIjij 12 CPI
15 CPI	ABCDEFGHIjij 15 CPI
PROPORTIONAL	ABCDEFGHIjij Proportional

## MODE Menu Group

The MODE menu group is selected when the MENU slide switch is at STYLE and the STYLE slide switch is set at MODE.

Table 2-4.  
MODE menu group.

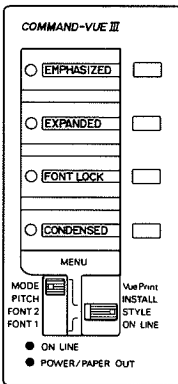

Key	With printer on line or off line
EMPHASIZED	Selects/cancels emphasized printing. The selected typeface is printed in bold.
EXPANDED	Selects/cancels expanded printing. The selected typeface is printed double-wide and double-high.
FONT LOCK	Selects/cancels font protection. If you select font lock, font-selection commands sent by your software are ignored; the printer uses the font you have selected with the control panel.
CONDENSED	Selects/cancels condensed printing, which compresses text to 60% of its standard width. This setting is ignored if 15 CPI is selected in the PITCH menu group.



When you select a mode with the control panel you cannot cancel it with a software command.

# INSTALL Menu Group

Move the MENU slide switch to INSTALL to enter the INSTALL menu group. This menu group lets you select among several optional accessories as well as selecting envelope-printing mode. Table 2-5 shows the functions available in the group.

Table 2-5.  
INSTALL menu group.

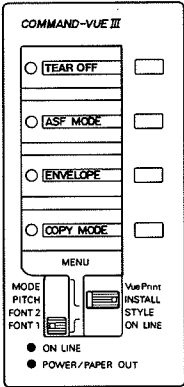

Key	With printer on line or off line
TEAR OFF	Selects/cancels tear mode, which should be used for advancing continuous forms to the tear bar.
ASF MODE	Selects/cancels the sheet feeder when the optional automatic sheet feeder (ASF) is installed.
ENVELOPE	Selects/cancels envelope mode, which should be used for printing envelopes. See "Printing on Envelopes" in Chapter 3 for more information.
COPY MODE	Selects/cancels copy mode, which should be used for printing multi-part forms.

# VuePrint™ Menu Group

The VuePrint Menu System is Citizen's unique feature for viewing and adjusting the printer's default settings. The settings you make on the other Command-Vue menus are temporary. They are lost whenever you turn the printer power off.

Settings you make on the VuePrint menu, however, are stored as a *macro* in the printer's permanent memory. (A macro is a complete set of printer settings

that describes the entire printer default environment.) This macro remains in memory when you turn the power off, and is automatically restored to the current settings area whenever you turn the power on. If you send software commands that override the macro (default) settings, you can then send a command to reset the printer (or turn off the printer), which causes the macro settings to be restored to the current settings area. You can also load the macro settings by pressing the SELECT and MENU keys for three seconds.



You can save your other Command-Vue menu settings to the macro memory (default settings) area. To do so, move the MENU slide switch to VuePrint, and then press the SAVE button for three seconds.

Enter the VuePrint menu group by moving the MENU slide switch to VuePrint.

Table 2-6.  
VuePrint menu group.

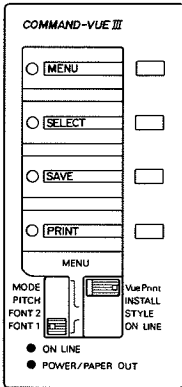

Key	With printer on line or off line
MENU	Enters the VuePrint menu system when pressed for three seconds. Advances to the next menu without changing the setting of the current menu.
SELECT	Moves the printhead to the next item in the current menu.
SAVE	Saves the selected item in the current menu as a default setting.
PRINT	Prints VuePrint default settings when pressed for three seconds.

**CITIZEN GSX-190**  
Default Setting Report

Default settings are EMPHASIZED.

<b>INSTALL</b>	<u>OFF</u>	ASF+ENV	ASF					
A.S.F.	<u>EPSON</u>	IBM						
EMULATION								
<b>PRINT STYLE</b>	<u>DRAFT</u>	HS-DRAFT	ROMAN	SANS SER	COURIER	PRESTIGE	SCRIPT	
FONT	ORATOR							
EMPHASIZED	<u>OFF</u>	ON						
PITCH	<u>10 CPI</u>	12 CPI	15 CPI	PROPORTIONAL				
FONT LOCK	<u>OFF</u>	ON						
<b>PAGE LAYOUT</b>	<u>6 LPI</u>	8 LPI						
LINE SPACING	5 INCH	7 INCH	<u>LETTER</u>	A4	12 INCH	LEGAL		
FORM LENGTH	<u>OFF</u>	ON						
PAGE SKIP								
<b>PRINT MODE</b>								
NLQ DIR	BI-DIR	<u>UNI-DIR</u>						
GRAPHIC DIR	BI-DIR	<u>UNI-DIR</u>						
<b>CHARACTER</b>								
SLASH ZERO	<u>OFF</u>	ON						
CHARACTER SET	<u>ITALICS</u>	GRAPHICS						
INTL CHAR SET	<u>U.S.A.</u>	FRANCE	GERMANY	U.K.	DENMARK1	SWEDEN	ITALY	
	SPAIN 1	JAPAN	NORWAY	DENMARK2	SPAIN 2	LATIN AM	LEGAL	
	KOREA	NETHER	TURKEY					
CODE PAGE	<u>U.S.A.</u>	MULTI	PORTUGAL	CANADA	NORWAY	SCANDNVA	TURKEY	
	ICELAND	WINDOWS						
<b>INSTALLING</b>								
TEAR OFF	<u>OFF</u>	ON						
PAPER OUT	DISABLE	<u>ENABLE</u>						
AUTO LF	<u>OFF</u>	ON						
COPY MODE	<u>OFF</u>	ON						
ENVELOPE	<u>OFF</u>	ON						

Figure 2-2. VuePrint default settings printout.

**CITIZEN GSX-190**  
VuePrint™ MENU SYSTEM

Use the SELECT key to point the print head to the desired setting.  
Use the SAVE key to store the new setting and go to the next menu.  
Use the MENU key to go to the next menu without storing a new setting.  
Use the MENU slide switch to exit this mode at any time.

Current settings are UNDERLINED. New settings will be **EMPHASIZED**.

<b>INSTALL</b>	<u>OFF</u>	ASF+ENV	ASF					
A.S.F.	<u>EPSON</u>	IBM						
EMULATION								
<b>PRINT STYLE</b>	<u>DRAFT</u>	HS-DRAFT	ROMAN	SANS SER	COURIER	PRESTIGE	SCRIPT	
FONT	ORATOR							

Figure 2-3. VuePrint waits for your selection for each menu.

To see a printout of the current default settings, press PRINT for three seconds. (See Figure 2-2.) The printer prints a default report, which lists all the VuePrint menus—one menu per line. The options in each menu are printed horizontally across the line, and the current default setting is underlined.

To change one or more default settings, press the MENU key for three seconds to enter the VuePrint menu system. (Be sure there is no data in the print buffer.) The MENU, SELECT, and SAVE lights flash, and the printer enters the VuePrint mode. It prints some helpful instructions followed by the options of the first menu, underlines the current setting, and awaits your instructions. See Figure 2-3.



You'll find it easier to see the printed menus and the option that the printhead is pointing to if you remove the top cover.

---

If you are happy with the current setting, simply press the MENU key. The printer retains this setting and advances to the next menu. It prints out the options of the next default menu, underlines the current setting, and awaits your instructions.

To change a setting, simply press the SELECT key until the printhead is beneath the option you desire, and then press SAVE. The printer fills in the new setting and advances to the next menu.



You can advance to the next menu without making changes by pressing the MENU key—even if you have moved the printhead with the SELECT key. However, as soon as you press the SAVE key, your new setting for the current menu item is stored in the printer's permanent memory.

---

Proceed through the default settings, menu by menu, until you have made all the changes you desire. You can exit the VuePrint menu system at any time by

moving the MENU slide switch. The printer also automatically exits the VuePrint menu system when you press MENU or SAVE at the last menu. Either way, the settings you have saved are retained in the printer's memory. The new default settings take effect the next time you power up the printer or when you load the macro.



Default settings are normally read during initial power up. The old default settings remain in effect until you turn the power off. If you wish to print with the new default settings, you must load them by pressing the SELECT and MENU keys for three seconds.

---

## VuePrint Menu Options

Many of the menus in the VuePrint menu system provide the same options as their Command-Vue menu counterparts. They also appear on the VuePrint menu so you can store those settings as part of your default macro; if you always use a color ribbon, for example, the VuePrint menu is the better way to make the setting. These menus, which are listed below, are described earlier in this chapter.

- A.S.F. (equivalent to ASF MODE on the INSTALL menu)



A.S.F. on the VuePrint allows you to select ASF for regular sheet feeders, or ASF+ENV for sheet feeders with an envelope feeder. Make this setting when you install your A.S.F.

---

- FONT (equivalent to the FONT 1 and FONT 2 menu groups)

- PITCH (equivalent to the PITCH menu group)
- FONT LOCK (equivalent to FONT LOCK on the MODE menu)
- ENVELOPE (see “Envelope Mode” in the “INSTALL Menu Group” section)

A few additional settings are available only through the VuePrint menu (or through software commands, which are explained in Appendix D). These settings are explained in Table 2-7.

Table 2-7.  
VuePrint  
menu options.

Menu	Description
Emulation	Selects Epson FX-800 commands or IBM Proprinter III commands. Be sure you select the same printer commands here as you have chosen in your software.
Line spacing	Selects 6 lines per inch (standard typewriter spacing) or 8 lines per inch. You can specify other spacing values with software commands.
Form length	Selects among several standard form lengths. Set this to match your paper size, whether you use continuous forms or single sheets.
Page skip (Epson emulation only)	Selects/cancels a bottom margin of one inch.
NLQ dir	Selects bidirectional or unidirectional printing of text. Bidirectional prints faster; unidirectional prints with better quality.
Graphic dir	Selects bidirectional or unidirectional printing of bit-image graphics.
Slash zero	Selects/cancels printing a slash through zeros so they are easily distinguished from the letter O.
Character set	Selects among different character sets.
International character set (Epson emulation only)	Selects among the foreign-language character sets.

Code page (IBM emulation only)	Selects among code pages, a method that DOS computers use to display and print foreign-language characters.
Tear off	Selects/cancels the feature where the GSX-190 advances continuous forms to the tear bar for easy removal after printing.
Paper out	Enables/disables the paper-out sensor.
Auto CR (IBM emulation only)	Automatically returns the printhead to the left margin after every line-feed command.
Auto LF	Automatically advances the paper one line after each carriage return command.

## Other Command-Vue Functions

In addition to the options and functions shown in the menu windows, the Command-Vue control panel performs some other functions that are not so obvious. These functions are summarized in Table 2-8.

Table 2-8.  
Other  
Command-Vue  
Functions.

Function	Procedure
Adjust top margin (top-of-form position)	With paper at the top-of-form position and the printer on line, press PARK/LOAD or LF/FF for three seconds. See "Top-of-Form Fine Adjustment" in Chapter 3 for more information.
Adjust tear-off position	With paper at the tear bar, press ON LINE and QUIET/SAVE for three seconds. See "PaperTear-Off Adjustment" in Chapter 3 for more information.
Clear print buffer	While the printer is off line, press QUIET/SAVE (in the ON LINE menu group) for more than three seconds.
Turn on color printing while printer is on line	Switch to Install menu, press COLOR RIBBON key for three seconds.
Hexadecimal dump of print stream	Press QUIET/SAVE while turning the printer power on. See "Hex Dump" in Appendix B for more information.



Print demo page	Switch to the VuePrint menu and press PRINT and SAVE for at least three seconds. The printer prints a test page that demonstrates its capabilities.
Print complete character set for current emulation	Press PRINT and SELECT keys for three seconds.
Print maintenance self test	Press ON LINE and LF/FF while turning the printer power on. See "Maintenance Test" in Appendix B for more information.
Print sliding character self test	Press ON LINE while turning the printer power on. See "Self Test" in Appendix B for more information.
Restore factory default settings	While the printer is on line, press PARK/LOAD, LF/FF, and QUIET/SAVE for more than three seconds.
Load macro	In the VuePrint menu, press SELECT and MENU for three seconds.
Save Command-Vue menu settings to macro memory	In the VuePrint menu, press SAVE for three seconds.

# Chapter 3

## Paper Handling

Your GSX-190 printer offers great versatility in the kinds of paper you can use and ways of loading and unloading them. This chapter discusses the detail of these features.

3

### Setting the Paper Thickness Lever

Paper up to .007 inches thick will feed smoothly through this printer. This allows you to use bond or ledger up to 27 lb. For thick paper, however, you need to adjust the print head away from the platen. Adjust the paper-thickness lever mounted on a notched brace at the left side of the printer. Move the lever toward the front of the printer for thicker paper.



---

Regardless of paper thickness, do not use a setting closer to the platen than the standard position pointer! Smudged output or damage to the printhead could result. See Table 3-1 for the recommended paper thickness settings for the number of copies you are using.

---

A small bump on the brace (see Figure 3-1) identifies the standard (zero) location that is appropriate for most papers. Use Table 3-1 to find the recommended setting for the paper you are using. How you install the tractor unit and load paper into the printer depends on what kind of paper you select. The tractor unit has two positions: push and pull.

The tractor unit is mounted in the push position at the factory. When installed, it fits snugly into the rear

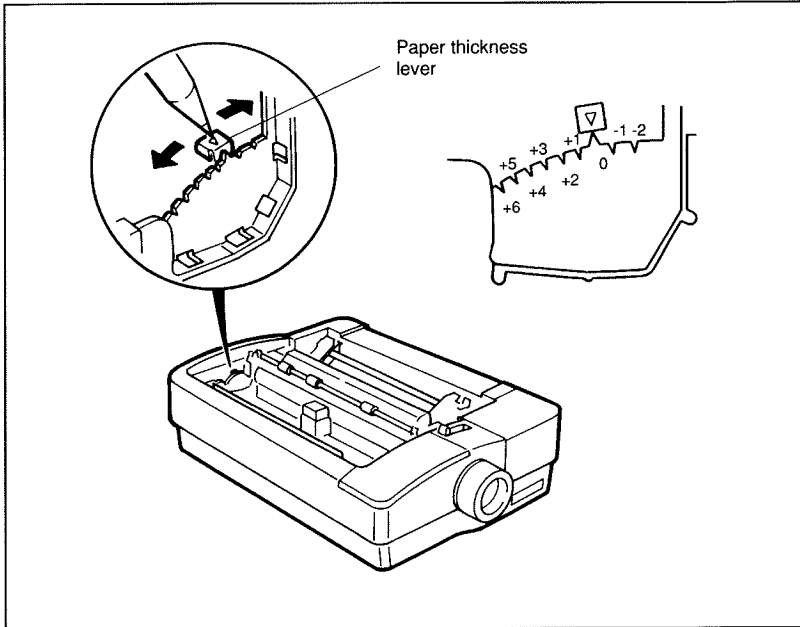

Figure 3-1. Location of paper thickness lever.

of the printer. It works by gripping the edges of the continuous paper and pushing it under and around the platen until the paper comes out the top of the printer.

Table 3-1.  
Paper  
thickness  
settings.

Paper thickness lever position	Number of copies (including original)
-2	Not used
-1	Not used
0	1 or 2
+1	3
+2	4 or envelope
+3	Envelope
+4	Envelope
+5	Envelope
+6	Envelope



You'll find that thicker paper feeds best when you use the bottom-feeding feature of the GSX-190.

## Setting the Paper Select Lever

The paper select lever (Figure 3-2 on page 28) sets the GSX-190 for either continuous or single sheet paper. If you look closely at the lever, you'll see what looks like a paper stack and single sheet of paper embossed next to the lever. The lever is moved forward (to the paper stack) for continuous paper and back (to the single sheet) for single sheets.

## Printing on Single Sheets

Single sheet feeding allows you to print on your company letterhead as well as many other types of paper that are not available as continuous paper. The GSX-190 can print on paper as narrow as 7.2 inches and can print up to 8 inches wide on paper as wide as 10.1 inches. Follow these steps:

1. Be sure the tractor is in the push position. (If not, follow the installation instructions later in this chapter.)



If you already have continuous paper loaded, simply press the PARK/LOAD key to back the paper out of the way. See "Paper Parking" in this chapter for more information.

---

2. Install the paper guide in the upright position used for inserting paper. See Figure 3-2. To do this, hold the paper guide so that the two corner extensions point downward into the printer. Slide the guide pins onto the L-shaped channel slot. At the same time, position the paper guide forward slightly allowing the pins to slip into the vertical channel. When installed correctly, the paper guide sits in an upright position.
3. Change the paper select lever to the rear (single sheet) position.

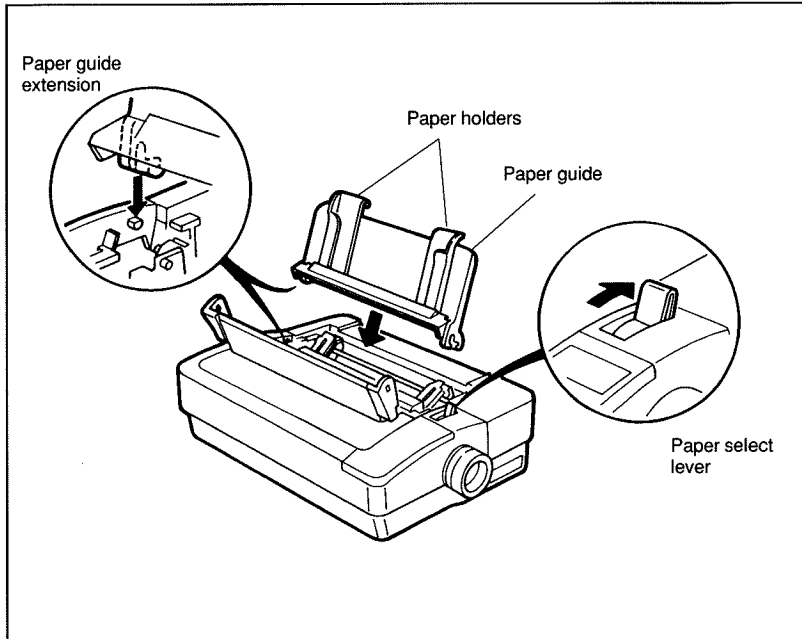

Figure 3-2. Installing the paper guide.

To use the paper guide, simply move the left paper holder to the left as far as it will go. This is the normal position, however, you can adjust it according to the size of paper you will be using. Insert a sheet of paper and adjust the right paper holder to the paper width.

4. Insert a piece of paper head in, face down, between the paper holders (as you would load paper in a typewriter). See Figure 3-3. Push the paper down gently to be sure it is all the way in.
5. Wait a brief time. The paper automatically feeds into the printer and stops when it reaches the correct position for the starting line of print.
6. Prepare to print by pressing the ON LINE key.

Your printer is now ready to receive data from your computer and print a document on single sheets. The

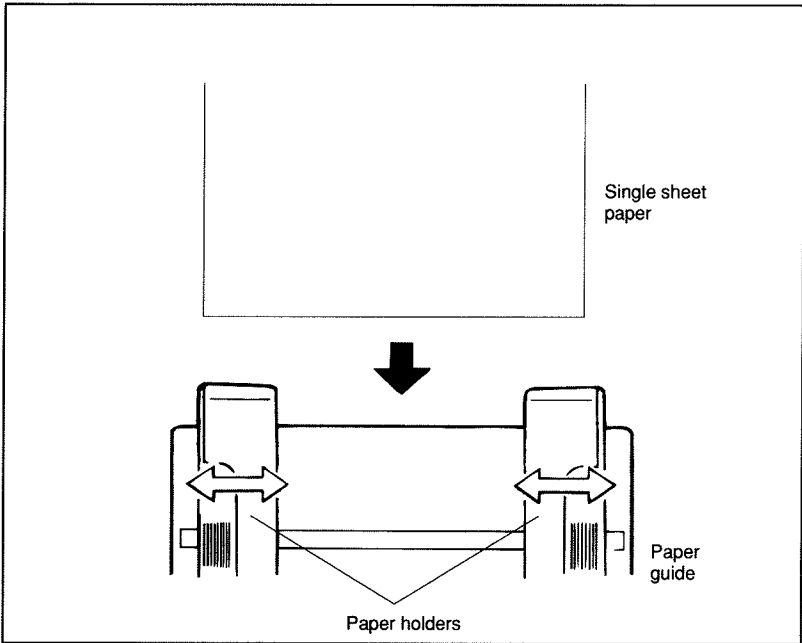

Figure 3-3. Adjusting the paper holders.

printer waits between pages for you to insert each new sheet and the control panel display reminds you to load paper by flashing the PAPER OUT indicator.

Loading single sheets repeatedly is faster and more efficient with the automatic sheet feeder or manual sheet feeder. Read more about them in Appendix A, "Options."

## The Tractor Unit

The tractor unit can be mounted in either the push or the pull position. (The tractor was mounted in the push position at the factory.) The tractor must always be in the proper position to suit the paper you're printing on. Use Table 3-2 to determine the correct tractor position.

Table 3-2.  
Paper  
handling  
summary .

Paper type	Tractor position	Paper-feed method	Paper select lever	Paper thickness lever
Continuous	Push	Rear	Front	0
Single-sheet	Push	Top	Back	0
Multi-copy*	Pull	Bottom	Front	+1 or +2
Labels	Pull	Bottom	Front	+1
Envelopes**	Push	Top	Back	+2 to +6

\* To print on 4-part forms set COPY MODE (on the STYLE menu) on.  
\*\* Set ENVELOPE (on the INSTALL menu) on.



When you load paper that is narrower than the capacity of the printer, place the paper near the left side of the printer. The paper-out sensor is about two inches from the left edge of the printer and the paper needs to cover it for successful operation.

## Installing the Tractor in the Push Position.

When the tractor is mounted in the push position, it holds the edges of the continuous paper and pushes it under and around the platen until the paper comes out the top. Follow the instructions below to change the tractor to the push position.

1. Remove any paper from the tractor.
2. With your thumbs on the release tabs and your fingers on the side of the printer, push the tractor rearward. The unit will easily pop off the locating tabs.
3. Set the tractor unit down in the rear printer opening. The front of the tractor edges should butt against the two locating pins that point outward from the sides of the mounting brace.
4. Place your forefingers between the ends of the tractor and the rear of the printer opening and

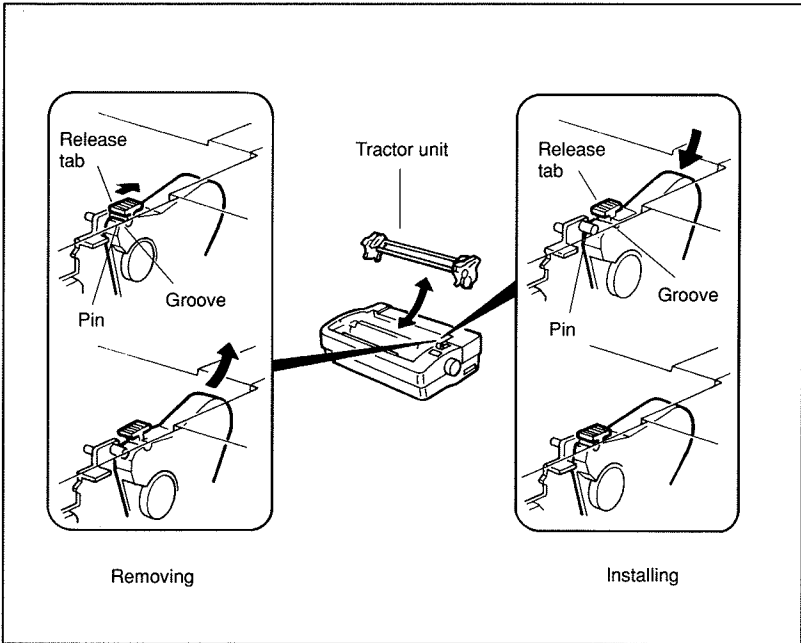

Figure 3-4. Removing and installing the tractor unit in the push position.

press the tractor forward until release tabs lock onto the locator pins.

## Installing the Tractor in the Pull Position

When the tractor is mounted in the pull position, it pulls the paper up from the bottom and sends it straight up past the platen. Use the pull position when you need a straighter paper path (as with labels). Follow the instructions below to change the tractor to the pull position.

1. Remove any paper from the tractor.
2. With your thumbs on the release tabs and your fingers on the side of the printer, push the tractor rearward. The unit will easily pop off the locating tabs.



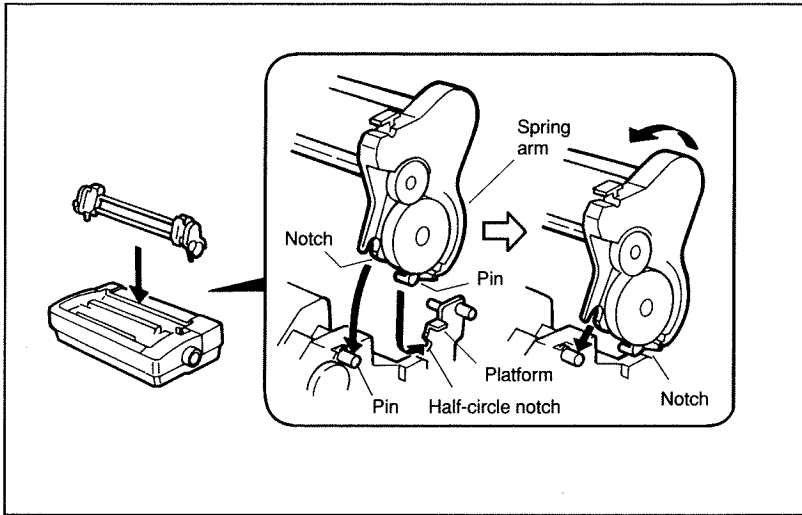

Figure 3-5. Installing the tractor unit in the pull position.

3. Hold the tractor unit so the sprockets face toward you and the round crossbar is above the square crossbar. Gently lower the tractor into the printer until each end of the tractor rests on the flats of the mounting brace.
4. Gently press the tractor down and slightly forward until the tractor's notches engage the forward locating pins.
5. Set the paper select lever to the forward (continuous-feed) position.

## Printing on Continuous Paper

Your printer can print up to 8 inches wide on continuous-feed paper that's from 4 to 10 inches wide. Standard continuous-feed paper can be fed from either the bottom or the rear. With rear-feeding you can take advantage of the GSX-190 special features of paper tear off, top-of-form fine adjustment and paper parking. You can stack the paper on the

desk or table behind the printer. (Be sure to allow space for the exiting paper so that it does not interfere with the incoming paper.) With bottom-feeding, you have convenient paper storage and less curling around the platen. We recommend the push position and rear feeding.



Because of the advanced paper-handling features of the GSX-190 it is seldom necessary to turn the paper feed knob. Most times turning the paper feed knob simply causes mis-aligned forms. Use the control panel instead.

---

Follow these steps to load continuous paper:

1. Be sure the tractor is mounted in the push position.
2. Move the paper select lever to the forward (paper stack) position.
3. Unlock the lock levers on the tractor feeders and adjust them to the approximate paper width. See Figure 3-6.
4. Open the tractor feeder covers and place the paper on the sprocket pins. Close the covers to clamp the paper.
5. Adjust the tractor feeders until the paper is just taut between them, and then relock the levers.
6. Install the paper guide/sheet separator in the sheet separator position see Figure 3-7. Do this by sliding the small pins that point into the printer onto the L-shaped channel openings on the outside of the paper guide extensions.

Lean the paper guide backward. At the same time, slide the paper guide forward slightly. Correctly installed, the paper guide lies flat on top of the printer case above the paper.

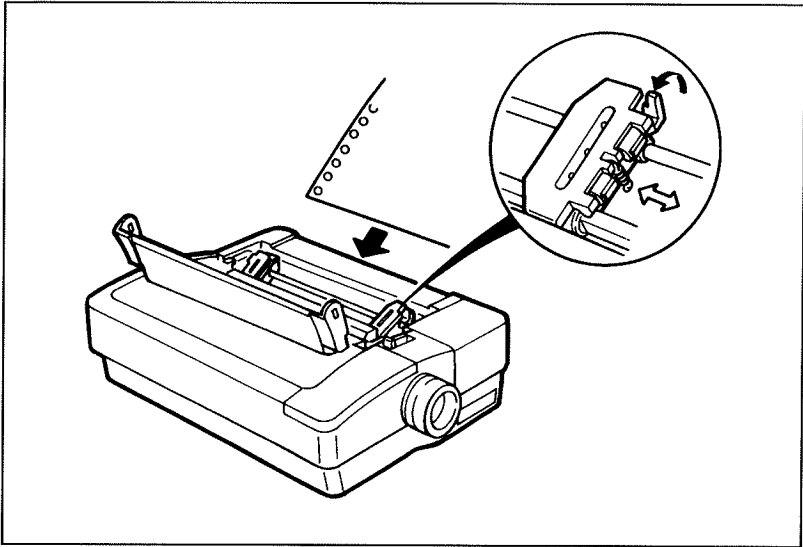

Figure 3-6. Adjusting the tractor feeders.

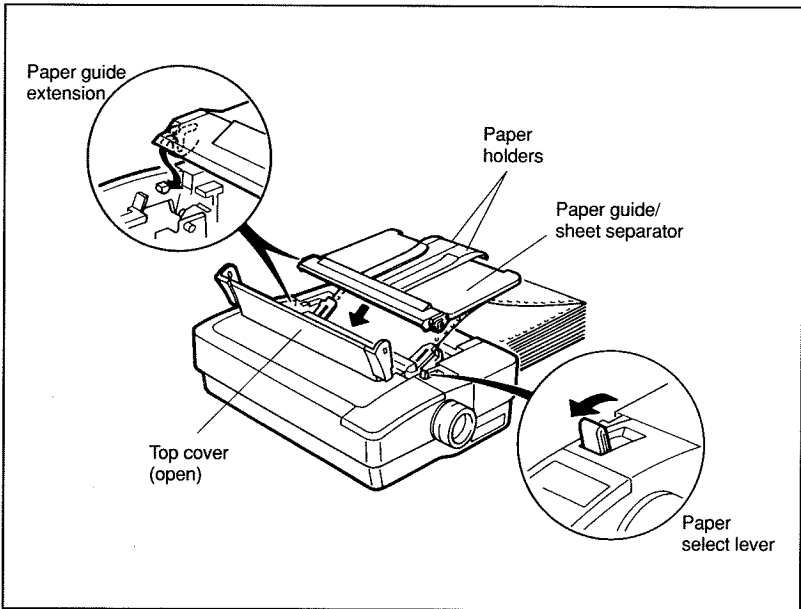

Figure 3-7. Installing the paper guide/sheet separator.

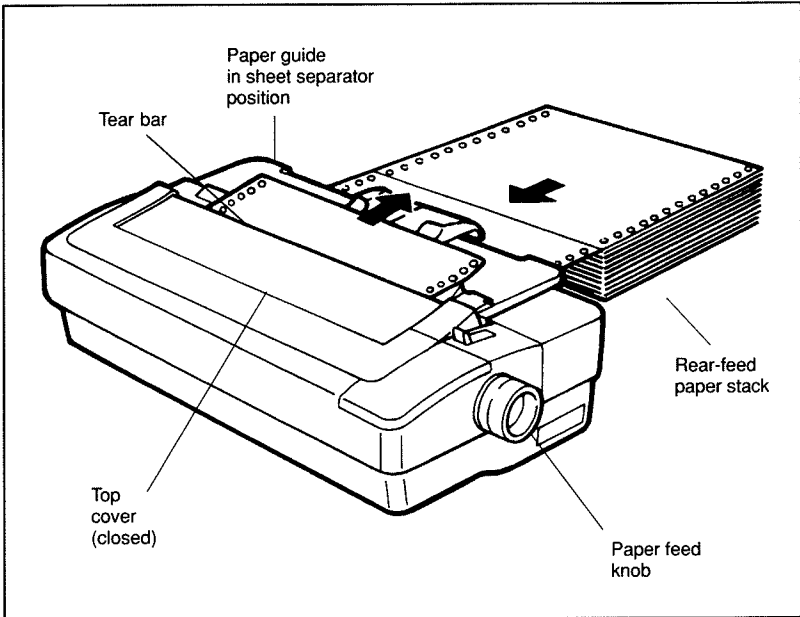

Figure 3-8. Continuous paper feeding into the rear of the printer.

7. Move the paper holders from the sides into the middle of the paper guide. This prevents your printed output from becoming accidentally jammed in the paper guide on its way out of the printer. See Figure 3-8.
8. Press the PARK/LOAD ▲ key. This advances the paper to the starting print position.
9. Press the ON LINE key.

## Paper Tear-Off

The top cover of your printer has a tear bar at the rear edge so you can easily tear off perforated sheets without wasting paper.

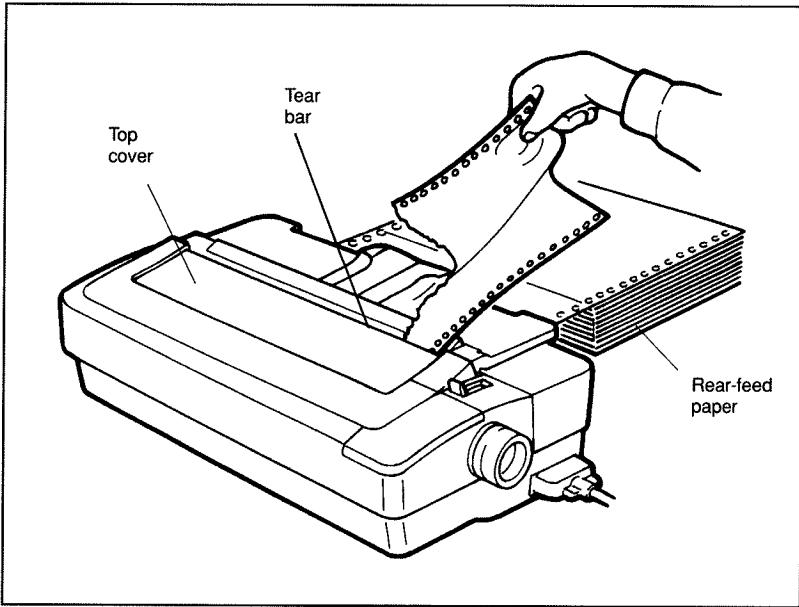

Figure 3-9. Using the tear bar.



You must be printing on continuous paper with the tractor unit in the push position to use this feature.

When your computer indicates the end of a print job (by sending a form feed command and no further data), the GSX-190 automatically advances the continuous paper so the perforation is at the tear bar. To remove the paper, just pull it across the tear bar. The printer automatically retracts to the correct top-of-form (starting position) when your computer starts the next print job.

Sometimes a print job will end in the middle of a page. To advance the paper to the tear-off-position, press the ON LINE key to take the printer off line, and then hold the LF/FF key for 2 to 3 seconds.

If the paper you are using does not advance to the perforation, check the length of the paper against the form length setting on your printer.



Occasionally, you may not want the paper to automatically advance to the paper tear-off. You can turn off this feature by changing TEAR OFF to OFF in the VuePrint menu.

## Paper Tear-Off Adjustment

The paper tear-off position is adjusted at the factory for standard continuous paper. When this is not suitable for the paper you're using, adjust the tear-off position by doing the following:

1. Load your paper with the tractor in the push position.
2. Make certain that the MENU slide switch is in the ON LINE position. Switch the printer off line.
3. Press the PARK/LOAD ▲ key to advance the paper to the tear bar.
4. Hold the ON LINE and QUIET/SAVE keys for three seconds. The PARK/LOAD and LF/FF indicators blink. Release the keys.
5. To adjust the edge of the paper upward to the tear bar by  $\frac{1}{72}$ -inch increments press the PARK/LOAD ▲ key. Pressing the LF/FF ▼ key adjusts the paper downward in  $\frac{1}{72}$ -inch increments.

To save your adjustment, press the QUIET/SAVE key. This setting remains in effect, even if you turn the printer off, until you repeat this procedure to set a different tear-bar position.

## Paper Parking

Paper parking is a convenient feature that allows you to switch quickly between continuous-feed paper

and single sheets. To use it, your continuous paper must be fed in through the rear of the printer with the tractor in the push position. This feature is disabled when the tractor is in the pull position.

It works by backing the continuous paper out of the printer to where it is no longer touching the platen. However, the paper remains in the tractor feeders, ready to feed into the printer.

To park your continuous paper:

1. After the current job finishes, tear off the paper after the last page. Press the ON LINE key to take the printer off line.
2. Press the PARK/LOAD ▲ key. The paper retracts to the parking position. The printer reverse feeds the paper a maximum of the current page length plus 6 inches.

You can now feed single sheets into the printer, following the directions earlier in this chapter. Remember to raise the paper guide from the paper separator position to the upright paper insertion position and change the paper select lever to the rear setting (for single sheets).

When you are ready to switch back to continuous paper, follow these steps:

1. Eject a single sheet of paper (if one remains inserted) by taking the printer off line and pressing the LF/FF ▼ key for 2 or 3 seconds.
2. Pull the paper select lever forward.
3. Press the PARK/LOAD ▲ key. The paper in the push tractor advances to the top-of-form.
4. Press the ON LINE key to print again on continuous paper.

## Printing on Envelopes

Single sheet feeding allows you to print on #10, #6<sup>3</sup>/<sub>4</sub>, #7<sup>3</sup>/<sub>4</sub>, and DL size envelopes with a paper weight of 12 to 20 lb.

Follow these steps:

1. Be sure the tractor is in the push position. (If not, follow the installation instructions earlier in this chapter.)



If you already have continuous paper loaded, simply press the PARK/LOAD key to back the paper out of the way. See "Paper Parking" in this chapter for more information

---

2. Change the paper select lever (shown in Figure 3-2) to the rear (single sheet) position.
3. Set the paper thickness lever to +2, +3, +4, +5 or +6, depending on the thickness of the envelope. Setting the paper thickness lever is critical to print quality when printing on envelopes. Experiment with several paper thickness settings and choose the one that best suits your particular envelope.
4. Install the paper guide in the upright position used for inserting paper. (See Figure 3-2 earlier in this chapter.)
5. Set the left paper holder (see Figure 3-10). Insert the envelope just enough to adjust the right paper holder to the envelope width; then, remove the envelope momentarily.
6. Open the flap of an envelope before inserting it.
7. Insert the envelope head in, face down, flap open between the paper holders (as you would load paper in a typewriter). See Figure 3-10. Push the



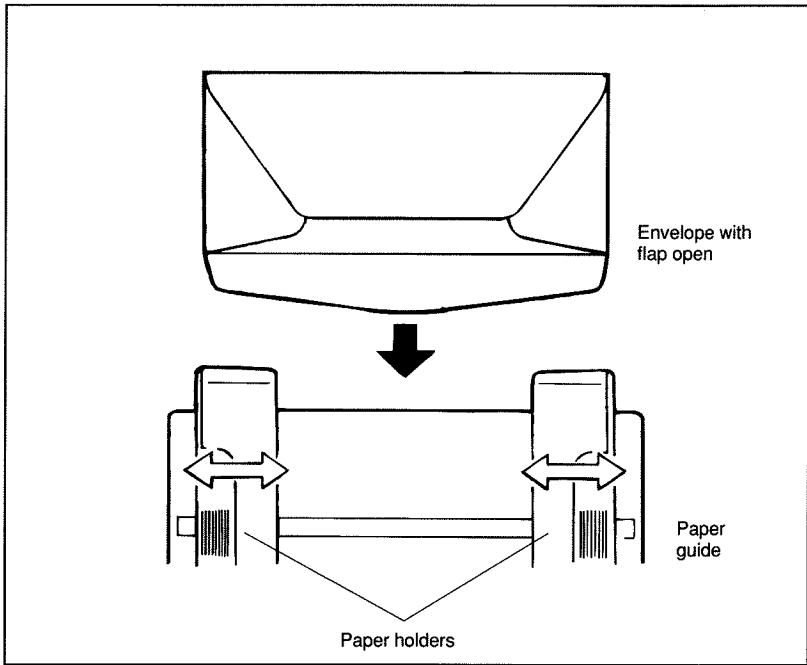

Figure 3-10. Adjusting the paper holders for printing with envelopes.

envelope down gently to be sure it is all the way in.

8. Wait a brief time (approximately half a second). The envelope automatically feeds into the printer and stops when it reaches the correct position for the starting line of print.
9. Move the MENU slide switch to INSTALL. Press the ENVELOPE key to turn envelope mode on.
10. Move the MENU slide switch back to ON LINE and press the ON LINE key.



We recommend that you set the VTOP option to +144 when printing on envelopes. This starts your printing on the envelope—not the flap. See “Top-of-Form Fine Adjustment” in this chapter for more information on VTOP settings.

Your printer is now ready. The printer waits between envelopes for you to insert each new one and the control panel display reminds you to load a new envelope by flashing the PAPER OUT indicator.

When printing on envelopes, avoid printing near edges of the envelope or in areas where the paper is triple thickness (glued together). Figure 3-11 shows the recommended printable area of a typical envelope.

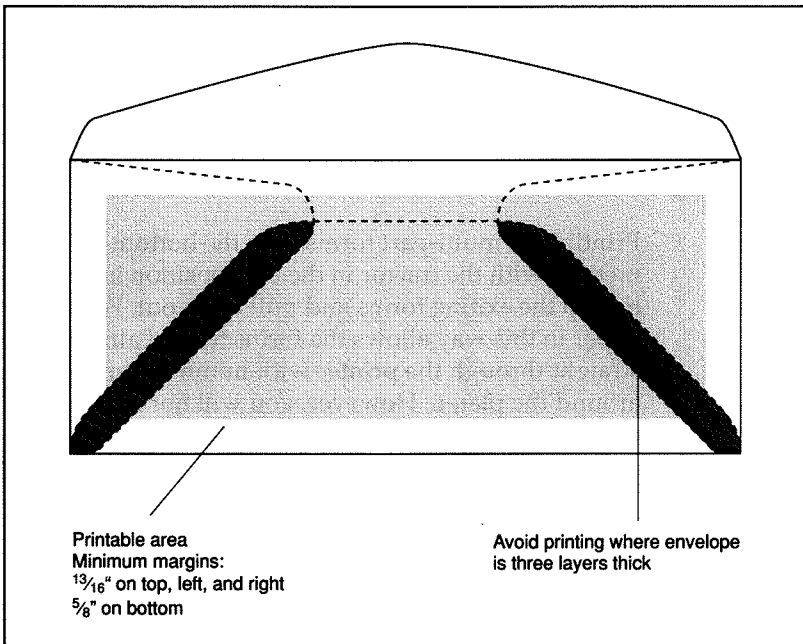

Figure 3-11. Printable area for envelopes.

## Printing on Overhead Transparencies

Your printer can also print in color on overhead transparencies for outstanding presentations. It's best to use transparencies specifically designed for dot matrix printers, such as Arkwright Dot Matrix Film (P/N 312-21-01) which have a slightly rough surface rather than a smooth surface.

To load transparencies, follow the instructions for "Printing on Single Sheets," earlier in this chapter.



Unlike paper, the ink on transparencies takes longer to dry. Be careful not to smudge the ink when handling newly printed transparencies.

For best results, select dark colors for printing, such as black, red, blue, or violet.

---

## Printing on Multi-part Forms and Labels

Printing on multi-part forms uses the bottom-feeding method with the tractor in the pull position in order to grip the exiting forms and pull them out. Feeding paper in this way allows the forms to feed almost straight through the printer with minimal curling around the platen. However, you will not be able to use the paper tear off, top-of-form fine adjustment, and paper parking features.

The printer is mounted on a printer stand allowing your supply of forms to sit below the printer.

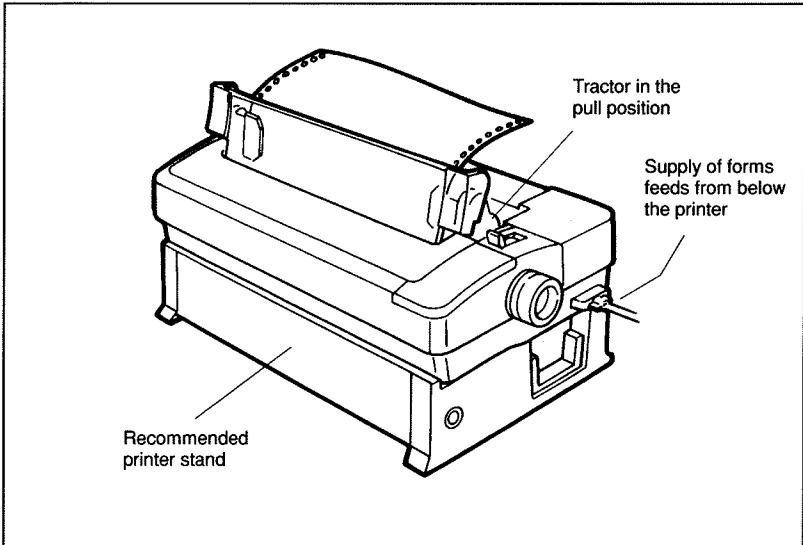

Figure 3-12. Bottom paper feeding.

Follow these steps to load multi-part forms or labels:

1. Be sure the tractor is in the pull position. If not, install it by following the instructions earlier in this chapter.
2. Turn off the printer before loading the forms or labels from the bottom.
3. Remove the top cover.
4. Set the printer on its rear side.
5. Insert the forms or labels through the slot in the bottom of the printer. See Figure 3-13. Pull the forms or labels through so that 4 or 5 inches extend out of the printer. Make sure the paper covers the paper out sensor, which is about 2 inches from the left side of the printer.
6. Set the printer right-side-up again.

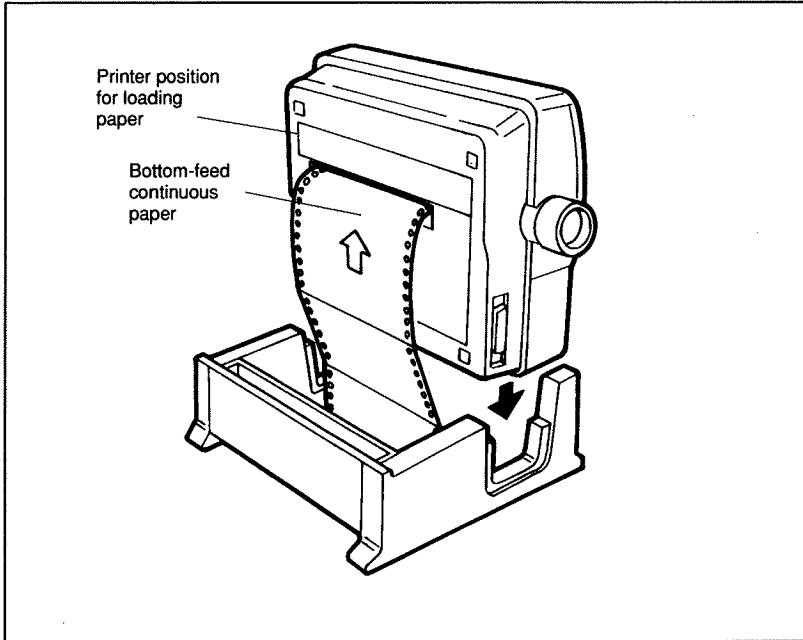

Figure 3-13. Feeding paper into the bottom of the printer.

7. Open the tractor feeder covers, position the forms or labels on the sprockets and close the covers. Be sure the paper is straight. Adjust the distance between the tractor feeders, if necessary, by unlocking the lock levers and sliding the feeders until the paper is taut. Relock the levers.
8. Move the paper select lever to the forward (paper stack) position.
9. Turn the paper feed knob until the labels are in the correct starting-print position or until the second set of forms is at the correct starting-print position. When printing with the tractor in the pull position, the first set of forms is unusable.
10. Set the paper thickness lever to +1 for labels or 3-part forms, +2 for 4-part forms. You may need to adjust this setting for best print quality.

11. Replace the top cover. The transparent part of the cover rests against the tractor unit.
12. Turn on the printer.

## Top-of-Form Fine Adjustment

You never need to use the paper feed knob for setting the top-of-form. You can make minute modifications to the top-of-form on continuous or single sheets by following these steps:



Your top margin is usually set by your software. You shouldn't need to change the top-of-form setting very often.

---

1. Load paper onto the push tractor or into the paper guide. If you are using single sheets, the paper automatically advances to the top-of-form, so skip the next step.
2. If you are using continuous paper, press the PARK/LOAD ▲ key to move the paper to the top-of-form position.
3. Press the ON LINE key to set the printer on line.
4. Press and hold the PARK/LOAD ▲ key or the LF/FF ▼ key for two to three seconds. This step directly enters the function to change the top-of-form position. The PARK/LOAD and LF/FF indicators blink to let you know you're in top-of-form fine adjustment mode.

The variable top-of-form setting of zero is the factory setting, which is approximately one inch from the edge of the paper to the top of a normal height character.

5. Press the PARK/LOAD ▲ key to adjust the paper upwards in  $\frac{1}{2}$ -inch increments. Or, you can press the LF/FF ▼ key to adjust the paper downwards in  $\frac{1}{2}$ -inch increments.

You can adjust the top-of-form from  $-\frac{60}{72}$  inch to  $+\frac{144}{72}$  inch.

6. Save your new top-of-form as the default setting by pressing the QUIET/SAVE key for about two seconds.



If you want to print on the first line on the paper, set variable top-of-form to  $-\frac{60}{72}$  inch.



If you want your new variable top-of-form to be only a temporary setting, do not press the QUIET/SAVE key. Simply press ON LINE. If you do not save it, the new variable top-of-form setting is discarded as soon as the printer is turned off.



You can set one variable top-of-form for single sheets and another for continuous paper and save both settings in one macro. The GSX-190 senses which variable top-of-form to use by the position of the paper select lever. This convenience eliminates the need to change the top-of-form each time you switch between continuous paper and single sheets.

---

When variable top-of-form is set between  $-24$  and  $-60$ :

- Print quality in the top  $\frac{6}{7}$  inch of the page may not be as good as the rest of the page.
- Occasional paper feeding problems may occur.
- Do not print in the first or last 1 inch (10 characters at 10 cpi) of the first two lines of the page as shown in Figure 3-14.

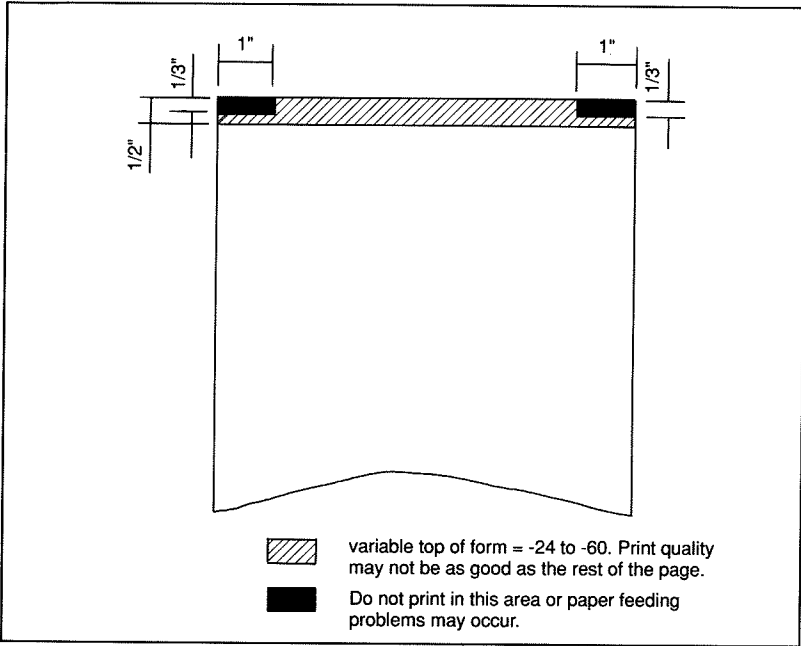

Figure 3-14. Extending the variable top of form setting.

Envelopes should not be used with -71 through -60 variable top-of-form settings. Paper feeding problems may occasionally occur.



The default top of form is 1". With 11" paper, this leaves you with 10" of printable area. Reduce the page height in your software to 10" to compensate.



A simple test of how your software and the GSX-190 work together is to create a document that's nothing but numbered lines from 1 to 66. Print this document to see what fits on a page.



You can reset top of form to its default position by holding the PARK/LOAD ▲ key until the paper is advanced as far as it will go. Then press the key again for 2 seconds. The paper will return to its default position.





# Chapter 4

## Setting Up Commercial Software

The GSX-190 is designed to work easily with many popular commercial software packages. The software is designed to print a file by sending codes for letters, numbers, punctuation, and so on in addition to activating various printer features. Some commands control rather simple features, such as ending a line or advancing the paper. Other commands control character pitch, font style, fine line spacing increments and graphics.

The commands to control these features are different on nearly every brand of printer. Citizen chose to use the same commands as the Epson FX-series, and the IBM Proprinter III—and then enhanced these command sets with extra commands that permit additional print styles, such as reverse (white on black) printing.

Printer drivers in your software are the easiest method for sending these commands to the printer; these generally offer support for the greatest number of printer features.

Other methods are to create your own printer driver, use embedded printer commands, or set up a group of commands that can be sent each time the program begins to print.

When you install new software, you are usually asked to select a driver from a list supplied by the software application. It helps to know what features

some of these drivers offer when you make your selection. Table 4-1 lists NLQ fonts feature associated with Citizen and Epson FX drivers.

The printer models in Table 4-1 are listed in order of their similarity to (i.e., compatibility with) the GSX-190. Therefore, as you search your software for the appropriate driver, you should look first for the printer model listed first. If it's not available, look for the second model, and so on.

*Table 4-1.  
Printer driver  
selection for  
the GSX-190.*

<b>Driver</b>	<b>NLQ fonts* feature</b>
Citizen GSX-190	YES
Citizen 200GX	YES
Citizen HSP-500	YES
Epson FX-850	YES
Epson LX-810	YES
Epson EX-800	YES
Epson JX-80	YES
*Some drivers may not support all of the GSX-190 NLQ fonts.	

If none of these drivers are listed by your software, choose any other Epson FX-series printer because Citizen uses the same commands.

If no Epson FX, EX or RX drivers are available, select IBM Proprinter III.

# Appendix A

## Option

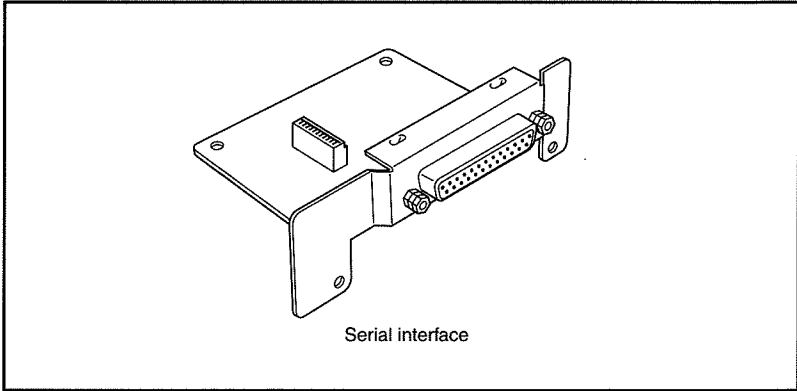

Figure A-1. Enhance your GSX-190 printer with the serial interface.

A

## Serial Interface

The serial interface permits your GSX-190 printer to communicate with a computer that requires an RS-232C serial interface. The serial interface supports speeds from 150 through 38400 baud, and it can use XON/XOFF and DTR protocols.

You can share your printer among two computers by using the serial interface; connect one computer to the parallel interface and one to the serial interface. The interface from which data is received first after the power is turned on is selected; the other interface is inactive.



The serial interface is not shipped with a serial interface cable. Contact your dealer for a null modem serial interface cable.

---

## Installing the serial interface

1. Turn the printer off.
2. Figure A-2 shows the serial interface cover, which is on the right side of your printer, near the rear. You must open it to install the serial interface. To open the cover, simply slide it to the right.

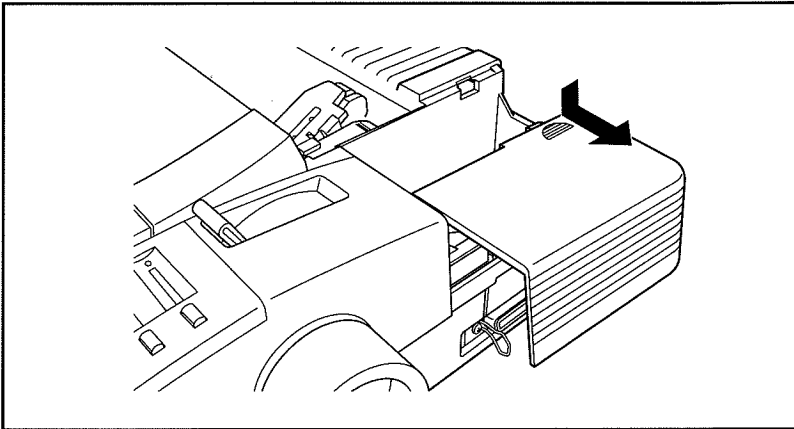

Figure A-2. Opening the serial interface cover.

3. Before installing the serial interface, push the small plastic barrier above the parallel (or USB) interface connector in gently until it brakes.
4. Installing the serial interface is two-stage process. You must connect the flat cable of the main board into the connector of the serial interface as shown in Figure A-3. Then set the serial interface board to the printer by four screws.

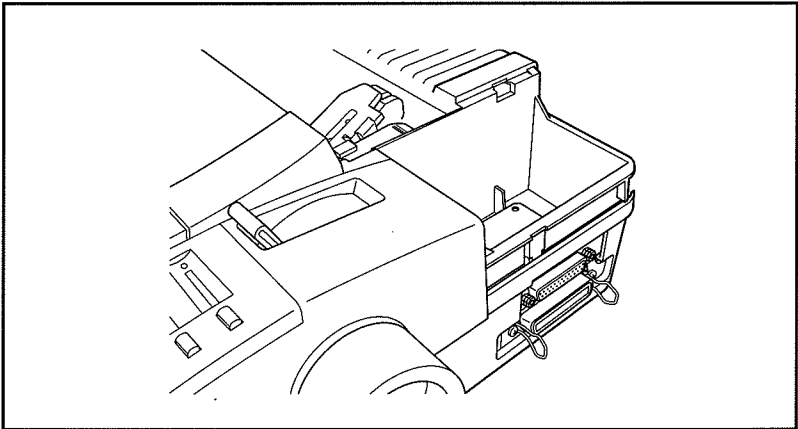
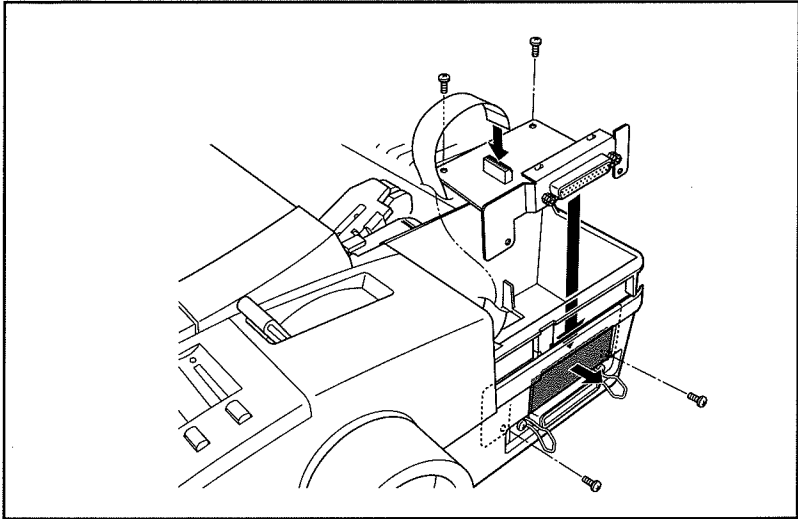

Figure A-3. Installing the serial interface.

The serial interface protocol will be automatically set to the factory default values during initial power up.

5. To get a printout of the current default setting, enter the VuePrint menu group by moving the MENU slide switch to VuePrint. Then press PRINT for three seconds. (See Page 17)





The serial interface protocol will be automatically set to the factory default values during initial power up.

CITIZEN GSX-190							
Default Setting Report							
Default settings are <u>EMPHASIZED</u> .							
<u>INSTALL</u>							
A.S.F.	OFF	ASF+ENV	ASF				
EMULATION	<u>EPSON</u>	IBM					
<u>PRINT STYLE</u>							
FONT	<u>DRAFT</u>	HS-DRAFT	ROMAN	SANS SER	COURIER	PRESTIGE	SCRIPT
	ORATOR						
EMPHASIZED	<u>OFF</u>	ON					
PITCH	<u>10 CPI</u>	12 CPI	15 CPI	PROPORTIONAL			
FONT LOCK	<u>OFF</u>	ON					
<u>PAGE SETUP</u>							
LINE SPACING	<u>6 LPI</u>	8 LPI					
FORM LENGTH	8 INCH	7 INCH	<u>LETTER</u>	A4	12 INCH	LEGAL	
PAGE SKIP	<u>OFF</u>	ON					
<u>PRINT MODE</u>							
NLQ DIR	SI-DIR	<u>UNI-DIR</u>					
GRAPHIC DIR	BI-DIR	<u>UNI-DIR</u>					
<u>CHARACTER</u>							
SLASH ZERO	<u>OFF</u>	ON					
CHARACTER SET	<u>ITALICS</u>	GRAPHICS					
INTL CHAR SET	<u>U.S.A.</u>	FRANCE	GERMANY	U.K.	DENMARK1	SWEDEN	ITALY
	SPAIN 1	JAPAN	NORWAY	DENMARK2	SPAIN 2	LATIN AM	LEGAL
	KOREA	NETHER	TURKEY				
CODE PAGE	<u>U.S.A.</u>	MULTI	PORTUGAL	CANADA	NORWAY	SCANDINAV	TURKEY
	ICELAND	WINDOWS					
<u>INSTALL</u>							
TEAR OFF	OFF	<u>ON</u>					
PAPER OUT	DISABLE	<u>ENABLE</u>					
AUTO LF	<u>OFF</u>	ON					
COPY MODE	<u>OFF</u>	ON					
ENVELOPE	<u>OFF</u>	ON					
<u>SERIAL</u>							
BAUD RATE	38400	19200	<u>9600</u>	4800	2400	1200	600
	300	150					
PARITY	NONE	ODD	EVEN				
DATA BIT	<u>8 BIT</u>	7 BIT					
STOP BIT	<u>1 BIT</u>	2 BIT					
PROTOCOL	<u>XON/XOFF</u>	DTR					

Figure A-4. VuePrint default settings printout.

- To change one or more default of the serial interface protocol, press the MENU key for three seconds to enter VuePrint mode system. Press the MENU key repeatedly until a menu which you plan to change is printed. See Page 18 for more details.

# Appendix B

## Maintenance

### Cleaning

Periodically clean out paper dust and other stray particles that may find their way into your printer. It is a good idea to keep your printer covered when it's not being used.



If the GSX-190 is used heavily or in a dusty environment, consult your service center for advice on periodic cleaning and lubrication.

---

1. Turn off the printer. Wipe the outside of the printer with a lint-free cloth that has been moistened with a mild detergent solution.
2. Remove the top cover, and remove the ribbon cassette.



Be sure the printhead is cool before performing any procedures inside the printer.

---

3. Use a soft brush to whisk paper lint and dust away from the area around the platen, printhead, and carriage shaft. Move the printhead as necessary, and take care not to damage the cables and pulleys.
4. Turn the paper feed knob, and wipe the surface of the platen with a soft cloth dampened with alcohol.
5. Reinstall the ribbon cassette and the top cover.



# Alarms

When an alarm occurs, the indicator lights shown in Figure B-1 will flash. The alarms you can receive, their probable causes, and remedies are listed below.



The position of the slide switches does not matter in this case. Figure B-1 shows the MENU switch in the ON LINE position and we'll use those labels to identify the indicator lights.

- Alarm:** POWER/PAPER OUT flashes.
- Cause:**
1. The printer is out of paper.
  2. The paper in the printer is jammed.
- Remedy:**
1. Load more paper.

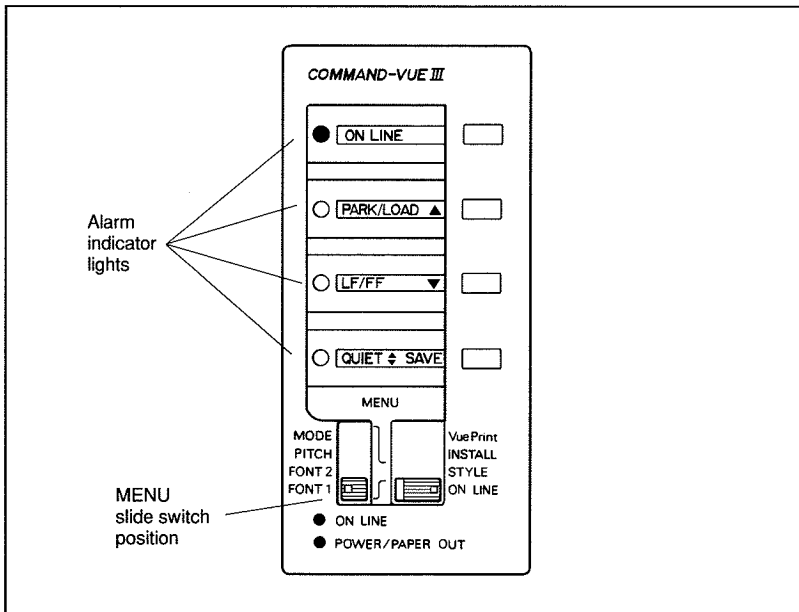

Figure B-1. Alarm indicator lights.

2. Clear the jam and reload paper.

*Alarm:* LF/FF and QUIET alternately flash.

*Cause:* This is a warning that the printhead is hot, which can occasionally happen during times of heavy printing.

*Remedy:* No action is required. The printer automatically resumes printing when the printhead has cooled.

*Alarm:* PARK/LOAD and LF/FF alternately flash.

- Cause:*
1. The paper select lever is set in the rear position while the tractor is installed in the push position.
  2. The paper select lever was moved after the paper was inserted into the printer.

- Remedy:*
1. Move the paper select lever forward if the tractor is in the pull position.
  2. Reset the paper select lever to its original position.
  3. Press the ONLINE key to continue printing.

*Alarm:* All indicators on.

*Cause:* Hardware error.

*Remedy:* Turn the printer off and then on again. If the problem still occurs, contact your dealer or Authorized Service Center.

*Alarm:* ON LINE and PARK/LOAD alternately flash.

*Cause:* The printhead was not positioned correctly.

**Remedy:** Press the ON LINE key to position the printhead correctly, or turn the printer off and then on again. If the problem still occurs, contact your dealer or Authorized Service Center.

## Troubleshooting

This section discusses some of the difficulties users sometimes encounter. All of the possible user actions are listed. *If these suggestions do not solve the problem, contact your dealer or Authorized Service Center. Do not try to repair the printer yourself.*

### Power

**Problem:** Printer is turned on but the POWER light on the control panel remains off.

- ✓ Check the power cord. Is it firmly connected to the wall outlet?
- ✓ Plug a lamp or other device into the wall outlet to be sure it is working.

### Paper Feeding

**Problem:** Continuous-feed paper jams.

- ✓ Are the tractor feeders locked?
- ✓ Is the paper select lever set to the forward (paper stack) position?
- ✓ Is the paper thickness lever correctly set for the type of paper you are using?
- ✓ Is the top cover installed and closed properly?
- ✓ Is the unprinted paper stack straight?

- ✓ Does the exiting paper have a clear path which does not interfere with the incoming paper?
- ✓ Is the incoming paper tangling with the power cord and/or computer cable?
- ✓ Is a label or other paper jammed under the platen?

*Problem:* Paper does not feed.

- ✓ Is your continuous paper set in the tractor feeders correctly?
- ✓ Be sure the paper select lever is in the correct position.

*Problem:* Paper parking does not operate or paper doesn't advance to the tear-off position.

- ✓ The paper select lever must be set for continuous paper (forward position) to park the paper.
- ✓ Check the tractor. It must be in the push position.
- ✓ Be sure the printer is off line.

*Problem:* Tear-off position is not at the perforation.

- ✓ Check the length of your paper against the setting made with the VuePrint menu. They must match.
- ✓ Be sure the A.S.F. selection (either the VuePrint menu or in the INSTALL menu) is off if the automatic sheet feeder is not installed.
- ✓ Perhaps you turned the paper feed knob manually, which should not be done.
- ✓ Try parking the paper again.

*Problem:* Paper does not feed from the automatic sheet feeder.

- ✓ Is the paper select lever in the rear (single sheet) position?

- ✓ Be sure the A.S.F. (automatic sheet feeder) is enabled by setting the VuePrint menu or the INSTALL menu.
- ✓ Be sure the paper loading lever of the automatic sheet feeder was not left in the “paper release” position?
- ✓ Turn off the printer and turn the paper feed knob clockwise. If the automatic sheet feeder ejection rollers DO NOT rotate, remove the ASF and reinstall it correctly.
- ✓ Be sure your software is set up for “Bin 1” or “Feeder.”

*Problem:* Paper does not feed from the manual sheet feeder.

- ✓ Be sure the A.S.F. (automatic sheet feeder) selection made with the Vueprint menu or the INSTALL menu is off.

*Problem:* An envelope feeds crooked.

- ✓ You should open the envelope flap before feeding.
- ✓ Is the paper select lever in the rear (single sheet) position?

## Printing Operation

*Problem:* Printhead does not move.

- ✓ Open the top cover and try turning the ribbon knob. If it is jammed, replace the ribbon cassette with a new one.
- ✓ Check inside the printer for excessive dust or dirt that may be restricting the printhead’s movement.

## Printing Results

*Problem:* Printer does not print at all.

- ✓ Is the ribbon cassette properly installed so that the ribbon feeds between the printhead and the ribbon mask (not between the ribbon mask and the black ribbon guide against the platen)?
- ✓ Be sure the printhead cables are attached to the printhead.

*Problem:* Printing is faint.

- ✓ Check the paper thickness lever for correct location.
- ✓ Remove the ribbon cassette and try turning the ribbon knob. If it is jammed, replace the cassette.

*Problem:* Printing is faint on fourth copy.

- ✓ Four-part forms should always be bottom-fed through the printer.
- ✓ Old carbonless forms don't create as dark an image as fresh forms.
- ✓ We recommend using the Sans Serif font because it is the most readable font.
- ✓ Adjust the paper thickness lever.
- ✓ Use copy mode and/or emphasized print.

*Problem:* Ink smudges on paper.

- ✓ Check the paper thickness lever. Adjust the lever 1 or 2 notches away from the platen when printing on thick paper or multi-part forms.
- ✓ Check that the envelope flap is open if you are printing on an envelope.

## Printing Characteristics

*Problem:* Printer does not produce expected printing characteristics.

- ✓ Be sure that the printer selected in your software matches the printer you have selected with the VuePrint menu. Refer to Chapter 4, "Setting Up Commercial Software."

*Problem:* The font setting on the Command-Vue control panel is canceled when you print with your word processing software.

- ✓ Your word processing software may be sending a reset command that cancels this control panel setting. Set FONT LOCK to on using the control panel to protect font settings from software override. See Chapter 2, "Command-Vue Control Panel."  
(FONT LOCK cannot protect a pitch setting. Set a pitch with your word processing software.)

## Self Tests

The self tests provide assurance that the printer is working. There are two self test patterns, a sliding character set, and an H-pattern. To print the sliding character set, hold the ON LINE key while you turn on the printer. To print the H-pattern, hold the ONLINE and LF/FF keys while you turn on the printer.

Interrupt the test by pressing the ON LINE key once. This interrupts the test print but does not actually stop it. If you wish to continue the test, press ON LINE again. When you want to discontinue the test, turn off the printer.

**B**

```
**** <CITIZEN> GSX-190 Printer ****
!"#%&'()*+,-./0123456789:;<=>?@ABCDEFGHIJKLMNopqRSTUVWxyz[\]^_`abcdefghijklmnop
!"#%&'()*+,-./0123456789:;<=>?@ABCDEFGHIJKLMNopqRSTUVWXYZ[\]^_`abcdefghijklmnop
!"#%&'()*+,-./0123456789:;<=>?@ABCDEFGHIJKLMNopqRSTUVWXYZ[\]^_`abcdefghijklmnopq
!"#%&'()*+,-./0123456789:;<=>?@ABCDEFGHIJKLMNopqRSTUVWXYZ[\]^_`abcdefghijklmnopq
!"#%&'()*+,-./0123456789:;<=>?@ABCDEFGHIJKLMNopqRSTUVWXYZ[\]^_`abcdefghijklmnopq
!"#%&'()*+,-./0123456789:;<=>?@ABCDEFGHIJKLMNopqRSTUVWXYZ[\]^_`abcdefghijklmnopq
```

Figure B-2. Self test (character set) pattern.

```
**** < CITIZEN > GSX-190 Printer ****
ROM Version    : AE20-0304          Date : JUL-25-2003
#####
#####
#####
#####
#####
```

Figure B-3. H-pattern test print.



## Hex Dump

The hex dump is a useful tool for debugging programs. It shows the hexadecimal values of the codes actually sent by your computer, printing 16 codes on each line. In addition, the character each code represents is printed at the right side of the sheet. Control codes—codes with hexadecimal value less than 20—are shown as periods. Figure B-4 is an example of the hex dump printout.

To enter hex dump mode, turn the printer power off. Then, while holding the QUIET key, turn on the printer. Send data from your computer.

Exit hex dump printing by turning the printer off.

```
***** < CITIZEN > GSX-190 Printer ***** HEXA DECIMAL DUMP
(0000) 1B 7E 35 30 1B 40 1B 55 31 1B 78 31 1B 6B 00 46 .~50.@.U1.x1.k.F
(0010) 6F 72 20 74 65 6E 20 74 68 6F 75 73 61 6E 64 20 or ten thousand
(0020) 76 65 61 72 73 20 77 65 20 68 61 76 65 0D 0A 62 years we have..b
(0030) 65 65 6E 20 73 68 61 70 69 6E 67 20 74 68 65 20 een shaping the
(0040) 65 6E 76 69 72 6F 6E 6D 65 6E 74 20 74 6F 0D 0A environment to..
(0050) 73 61 74 69 73 66 79 20 6F 75 72 20 69 6D 6D 65 satisfy our imme
(0060) 64 69 61 74 65 20 6E 65 65 64 73 2E 20 42 79 0D diate needs. Ey.
(0070) 0A
```

Figure B-4. Sample hex dump.

## Character Set

You can print a complete character set for the current emulation. Simply hold the PRINT and SELECT keys for three seconds. It will print the character set in the currently selected font.

# Appendix C

## Specifications

### Printing

Printing Speed	Draft characters:	15 CPI:	270 CPS
		12 CPI:	216 CPS
		10 CPI:	240 CPS (high speed)
	Near Letter quality (NLQ):	10 CPI:	180 CPS
		15 CPI:	68 CPS
		12 CPI:	54 CPS
	10 CPI:	45 CPS	
Buffer Memory	8K bytes		
Emulations	Epson FX-850, EX-800, IBM Proprinter III		

### Character Sets

Epson Emulation	Epson italic, Epson graphics, international characters for 16 languages, legal symbols, Windows ANSI (USA)	
IBM Emulation	Code pages 437, 850, 860, 861, 863, 865, Turkish, Scandinavian, Windows ANSI (USA)	
Column Width (8 inches)	<b>CPI</b>	<b>Column width</b>
	10	80
	12	96
	15	120
	17.1	137
	20	160
Line Spacing	1/6, 1/8, 7/72 (standard), <i>n</i> /72 <i>n</i> /144, or <i>n</i> /216 inch programmable	

NOTE: CPI stands for Characters Per Inch; CPS stands for Characters Per Second

Bit Image Modes (Horizontal) 60, 72, 80, 90, 120, 144, and 240 dots per inch

## Paper

Continuous forms	Width: 4-10 inches Weight: 14-27 lbs. (single-part) Thickness: Up to 4 parts, maximum form thickness 0.2mm
Single sheets	Width: 7.2-10 inches Weight: 14-27 lbs.

## Printer

Dimensions  
Height: 5.4 inches (136 mm)  
Width (including knob): 17.0 inches (432 mm)  
Depth: 12.6 inches (320 mm)

Weight 11.5 lbs. (5.2 kg)

Power Requirements 115V  $\pm$ 10%, 60  $\pm$ 3 Hz

Power Consumption  
At standby: 10 W  
During printing of ASCII 96 sliding pattern: 38 W

Environment  
Temperature: Operating: 41 to 95°F (5 to 35°C)  
Storage: -22 to 140°F (-30 to 60°C)  
Relative Humidity: Operating: 10 to 80%  
Storage: 5 to 85%

Printer MTBF 4,000 hours (Excluding Printhead)

Printer MTTR 20 minutes or less

Printhead Life 200 million strokes per wire

## Parallel Interface

Interface Centronics-compatible  
(conformity to IEEE 1284 nibble Ecp)

Cable IBM parallel printer cable equivalent (cable length not to exceed 10 feet)

Connector 57-30360 Amphenol

# USB Interface

Interface	USB (conformity to version 1.1)
Connector (printer side)	Series B
Data transmission type	Control/Bulk transmission

# Serial Interface

Protocol	X-ON/X-OFF, READY/BUSY
Baud rate	4800, 9600, 19200, 38400
Data length	7 or 8 bits

# FCC COMPLIANCE STATEMENT

This equipment has been tested and found to comply with the limits for a Class B Digital device, pursuant to Part 15 of the FCC Rules. These limits are designed to provide reasonable protection against harmful interference in a residential installation. This equipment generates, uses and can radiate radio frequency energy and, if not installed and used in accordance with the instructions, may cause harmful interference to radio communications. However, there is no guarantee that interference will not occur in a particular installation. If this equipment does cause harmful interference to radio or television reception, which can be determined by turning equipment off and on, the user is encouraged to try to correct the interference by one or more of the following measures:

- Reorient or relocate the receiving antenna.
- Increase the separation between the equipment.
- Connect the equipment into an outlet on a circuit different from that to which the receiver is connected.
- Consult the dealer or an experienced radio/TV technician for help.

**CAUTION:**

The use of a non-shielded interface cable with this equipment is prohibited. Only peripherals (computer input/output devices, terminals, etc.) certified to comply with the limits for the Class B digital device may be attached to this computer peripheral. Operation with non-certified peripherals is also likely to result in harmful interference to radio and TV reception.



## EMI COMPLIANCE STATEMENT

This equipment generates and uses radio frequency energy and if not installed and used properly, that is, in strict accordance with the manufacturer's instructions, may cause interference to radio and television reception.

This digital apparatus does not exceed the Class B limits for radio noise emissions from digital apparatus set out in the Radio Interference Regulations of the Canadian Department of Communications.

This equipment is designed to provide reasonable protection against such interference in a residential installation. However, there is no guarantee that interference will not occur in a particular installation. If this equipment does cause interference to radio or television reception, which can be determined by turning the equipment off and on, the user is encouraged to try to correct the interference by one or more of the following measures:

- Reorient the receiving antenna
- Relocate the computer with respect to the receiver
- Move the computer into a different outlet so that computer and receiver are on different branch circuits.

## ETAT DE CONFORMITE EMI A L'USAGE

Cet équipement produit et utilise l'énergie à radiofréquences et s'il n'est pas installé et utilisé correctement, c'est à dire en accord strict avec les instructions du fabricant, il risque de provoquer des interférences avec la réception de la radio et de la télévision. Le présent appareil numérique n'émet pas de bruits radioélectriques dépassant les limites applicables aux appareils numériques de la classe B prescrites dans le Règlement sur le brouillage radioélectrique édicté par le ministère des Communications du Canada.

Cet équipement est conçu pour fournir une protection satisfaisante contre de telles interférences dans une installation résidentielle. Cependant, il n'y a pas de garantie contre les interférences avec les réceptions radio ou télévision, provoquées par la mise en et hors circuit de l'équipement; aussi, il est demandé à l'utilisateur d'essayer de corriger l'interférence par l'une ou plus des mesures suivantes:

- Réorienter l'antenne de réception.
- Installer l'ordinateur autre part, par égard pour le récepteur.
- Brancher l'ordinateur dans une prise de courant différente de façon à ce que l'ordinateur et le récepteur soient branchés sur des circuits différents.

# Appendix D

## Command Reference

In the following tables, ESC indicates the Escape character. Braces around a number, for example {24}, indicates that you should use the character with that decimal value.

### Citizen Commands

Citizen commands work in both emulations.

#### Printer Control Commands

High speed draft mode	On	ESC ~ 8 1
	Off	ESC ~ 8 0
Top-of-form position	$\frac{1}{16}$ inch	ESC ~ T 1
	1 inch	ESC ~ T 0
Top-of-form adjustment	Continuous forms	ESC ~ V n 0
	Single sheets	ESC ~ V n 1
Park continuous paper		ESC ~ {12}
Paper tear-off	Enable	ESC ~ C 1
	Disable	ESC ~ C 0
Copy mode	On	ESC ~ !1
	Off	ESC ~ !0
Font lock	On	ESC ~ F 1
	Off	ESC ~ F 0
Emulation	Epson FX-850	ESC ~ 5 0
	IBM Proprinter III	ESC ~ 5 1

#### Vertical Motion Commands

Line spacing	$n/144$ inch	ESC ~ 0 n
--------------	--------------	-----------

#### Print Style Commands

Select font	Roman	ESC ~ x 0
	Sans serif	ESC ~ x 1
	Courier	ESC ~ x 2
	Prestige	ESC ~ x 3
	Script	ESC ~ x 4

	Orator	ESC ~ x 7
<b>Print Size Commands</b>		
Pitch	Pica	ESC ~ 3 0
	Elite	ESC ~ 3 1
	13.3 pitch	ESC ~ 3 5
	Fifteen pitch	ESC ~ 3 6
	17 pitch	ESC ~ 3 2
	20 pitch	ESC ~ 3 7
Expanded print	On	ESC ~ 1 3
	Off	ESC ~ 1 0
Quadruple width print	On	ESC ~ 1 4
	Off	ESC ~ 1 0
Double-high print	On	ESC ~ 1 1
	Off	ESC ~ 1 0
Double-high, double wide print	On	ESC ~ 1 5
	Off	ESC ~ 1 0
Quadruple-high print	On	ESC ~ 1 2
	Off	ESC ~ 1 0
Quadruple-high, quadruple-wide print	On	ESC ~ 1 6
	Off	ESC ~ 1 0

### Print Enhancement Commands

Reverse print	On	ESC ~ 2 1
	Off	ESC ~ 2 0

### Character Table Commands

Zero	Slashed	ESC ~ 4 1
	Not slashed	ESC ~ 4 0
Select code page	USA (437)	ESC ~ R 0
	Multilingual (850)	ESC ~ R 1
	Portugal (860)	ESC ~ R 2
	Canada-French (863)	ESC ~ R 3
	Norway (865)	ESC ~ R 4
	Scandinavia	ESC ~ R 5
	Turkish	ESC ~ R12
Icelandic (861)	ESC ~ R13	
Select Widnows ANSI		
Character set		ESC ~ s
Print complete character set		ESC ~ S

# Epson FX-850 Emulation Commands

## Printer Control Commands

Master reset		ESC @
Delete character		{127}
Cancel line		{24}
Unidirectional print	On	ESC U 1
	Off	ESC U 0
	One line	ESC <
Half speed mode	On	ESC s 1
	Off	ESC s 0
Immediate mode	On	ESC i 1
	Off	ESC i 0
Paper-out sensor	Enable	ESC 9
	Disable	ESC 8
Select/deselect	Deselect	{19}
	Select	{17}
MSB control	MSB = 1	ESC >
	MSB = 0	ESC =
	Cancel MSB control	ESC #

## Vertical Motion Commands

Advance paper	One line	{10}
	<i>n</i> lines	ESC f {1} <i>n</i>
	To next TOF	{12}
	<i>n</i> /216 inch	ESC J <i>n</i>
	To next vertical tab position	{11}
Retract paper	<i>n</i> /216 inch	ESC j <i>n</i>
Set page length	<i>n</i> lines	ESC C <i>n</i>
	<i>n</i> inches	ESC C {0} <i>n</i>
Skip-over-perforation	<i>n</i> lines	ESC N <i>n</i>
	Cancel	ESC O
Line spacing	1/6 inch	ESC 2
	1/8 inch	ESC 0
	7/72 inch	ESC 1
	<i>n</i> /72 inch	ESC A <i>n</i>
	<i>n</i> /216 inch	ESC 3 <i>n</i>
Set vertical tabs	In channel 0	ESC B <i>n</i> 1 <i>n</i> 2 ... {0}
	In channel <i>c</i>	ESC b <i>c</i> <i>n</i> 1 <i>n</i> 2 ... {0}
	Every <i>n</i> lines	ESC e {1} <i>n</i>



Select vertical tab channel ESC / c

### Horizontal Motion Commands

Move printhead	To left margin	{13}
	Backspace	{8}
	<i>n</i> columns to the right	ESC f {0} <i>n</i>
	To next horizontal tab position	{9}
	Absolute position	ESC \$ <i>n1 n2</i>
	Relative position	ESC \ <i>n1 n2</i>
Margins	Left	ESC l <i>n</i>
	Right	ESC Q <i>n</i>
Set horizontal tabs	Column <i>n1, n2, etc.</i>	ESC D <i>n1 n2 ... {0}</i>
	Every <i>n</i> columns	ESC e {0} <i>n</i>

### Print Style Commands

Select print quality	Near letter quality	ESC x 1
	Draft	ESC x 0
Select font	Roman	ESC k 0
	Sans serif	ESC k 1
	Courier	ESC k 2
	Prestige	ESC k 3
	Script	ESC k 4
	Orator	ESC k 7
Select print style	<i>n</i> = sum of attributes	ESC ! <i>n</i>
	Elite	1
	Proportional	2
	Condensed	4
	Emphasized	8
	Doublestrike	16
	Expanded	32
	Italic	64
	Underline	128

### Print Size Commands

Pitch	Pica	ESC P
	Elite	ESC M
	Fifteen pitch	ESC g
Expanded print	On	ESC W 1
	Off	ESC W 0
Expanded print (one line)	On	{14}
	Off	{20}
Condensed print	On	{15}
	Off	{18}
Proportional spacing	On	ESC p 1
	Off	ESC p 0
Double-high print	On	ESC w 1
	Off	ESC w 0

## Print Enhancement Commands

Emphasized print	On	ESC E
	Off	ESC F
Doublestrike print	On	ESC G
	Off	ESC H
Italic print	On	ESC 4
	Off	ESC 5
Underlining	On	ESC - 1
	Off	ESC - 0
Superscript/subscript	Superscript	ESC S 0
	Subscript	ESC S 1
	Off	ESC T
Justification	Flush left	ESC a 0
	Centered	ESC a 1
	Flush right	ESC a 2
	Justified left and right	ESC a 3
Set intercharacter spacing		ESC (space) <i>n</i>

## Character Table Commands

Characters 128-255	Italics	ESC t {0}
	Epson graphics characters	ESC t {1}
Characters 128-159	Control codes	ESC 7
	Printable characters	ESC 6
Select character set	USA	ESC R {0}
	France	ESC R {1}
	Germany	ESC R {2}
	United Kingdom	ESC R {3}
	Denmark I	ESC R {4}
	Sweden	ESC R {5}
	Italy	ESC R {6}
	Spain I	ESC R {7}
	Japan	ESC R {8}
	Norway	ESC R {9}
	Denmark II	ESC R {10}
	Spain II	ESC R {11}
	Latin America	ESC R {12}
	Korea	ESC R {13}
Legal	ESC R {64}	
Expand code area	Printable codes	ESC I 1
	Control codes	ESC I 0

## Download Character Commands

Download characters	Define character	ESC & {0} <i>data</i>
	Copy ROM to RAM	ESC : {0} <i>n</i> {0}
	Select download characters	ESC % 1
	Cancel download characters	ESC % 0

## Graphics Commands

Bit image graphics	Single-density	ESC K <i>n1 n2 data</i>
	Double-density	ESC L <i>n1 n2 data</i>
	Hi-speed dbl-density	ESC Y <i>n1 n2 data</i>
	Quadruple-density	ESC Z <i>n1 n2 data</i>
	Graphics mode <i>m</i>	ESC * <i>m n1 n2 data</i>
	Reassign graphics mode	ESC ? <i>n m</i>
	9-pin graphics	ESC ^ <i>m n1 n2 data</i>

# IBM Proprinter III Emulation Commands

## Printer Control Commands

Initialize printer		ESC [ K <i>c</i> {0} <i>int</i> {3} <i>p1 p2</i>
Cancel line		{24}
Unidirectional print	On	ESC U 1
	Off	ESC U 0
Automatic line feed	On	ESC 5 1
	Off	ESC 5 0
Select/deselect	Deselect	{19}
	Deselect	ESC Q {3}
	Select	{17}

## Vertical Motion Commands

Advance paper	One line	{10}
	To next TOF	{12}
	<i>n</i> /216 inch	ESC J <i>n</i>
	To next vertical tab position	{11}
Set top-of-form position		ESC 4
Set page length	<i>n</i> lines	ESC C <i>n</i>
	<i>n</i> inches	ESC C {0} <i>n</i>

Skip-over-perforation	<i>n</i> lines	ESC N <i>n</i>
	Cancel	ESC O
	Start text line	
Line spacing	spacing	ESC 2
	1/8 inch	ESC 0
	7/72 inch	ESC 1
	<i>n</i> /72 inch	ESC A <i>n</i>
	<i>n</i> /216 inch	ESC 3 <i>n</i>
Vertical tabs	Set vertical tabs	ESC B <i>n1 n2 ...</i> {0}
	Clear all tabs	ESC R

## Horizontal Motion Commands

Move printhead	To left margin	{13}
	Backspace	{8}
	To next horizontal tab position	{9}
Left and right margins		ESC X <i>l r</i>
Horizontal tabs	Set horizontal tabs	ESC D <i>n1 n2 ...</i> {0}
	Clear all tabs	ESC R

## Print Style Commands

Select font	Draft 10 pitch	ESC I {0}
	High-speed draft 12	
	pitch	ESC I {1}
	NLQ	ESC I {2}
	NLQ II	ESC I {3}
	NLQ italic	ESC I {11}

## Print Size Commands

Pitch	Pica	{18}
	Elite	ESC :
	Condensed	{15}
Expanded print	On	ESC W 1
	Off	ESC W 0
Expanded print (one line)	On	{14}
	Off	{20}
Proportional spacing	On	ESC P 1
	Off	ESC P 0
		ESC [ @ {4} {0} {0} {0} <i>n1 n2</i>

## Print Enhancement Commands

Emphasized print	On	ESC E
	Off	ESC F
Doublestrike print	On	ESC G
	Off	ESC H
Underlining	On	ESC - 1
	Off	ESC - 0

Overscoring	On	ESC _ 1
	Off	ESC _ 0
Superscript/ subscript	Superscript	ESC S 0
	Subscript	ESC S 1
	Off	ESC T

## Character Table Commands

Select character set	Set 1	ESC 7
	Set 2	ESC 6
Print All Characters		
Set	Continuous	ESC \ n1 n2
	One character	ESC ^ n

## Download Character Commands

Define characters		ESC = <i>data</i>
Select download characters	Draft 10 pitch	ESC I {4}
	High-speed draft 12 pitch	ESC I {5}
	NLQ	ESC I {6}
	NLQ II	ESC I {7}
	Italic	ESC I {15}

## Graphics Commands

Bit image graphics	Single-density	ESC K n1 n2 <i>data</i>
	Double-density	ESC L n1 n2 <i>data</i>
	Hi-speed	
	dbl-density	ESC Y n1 n2 <i>data</i>
	Quadruple-density	ESC Z n1 n2 <i>data</i>

# Index

## A

Accessories, ordering viii  
Alarms 56-58  
ASF MODE key 17  
Auto CR 23  
Auto LF 23

## B

Bottom feeding  
    *See* Paper, bottom feeding  
Buffer, clearing 23

## C

Cable, parallel interface 7-8  
Cautions vii  
Character sets 22, 24, 65  
Cleaning 55  
Code page 22, 65  
Command-Vue 11, 13-24  
    FONT 1 menu 14-15  
    FONT 2 menu 14-15  
    INSTALL menu 17  
    keys 11  
    menu lights 11  
    menu windows 11  
    MODE menu 16  
    *See also* names of keys  
    ON LINE menu 13-14  
    PITCH menu 15  
    slide switches 11  
    VuePrint menu 17-24  
Command-Vue control panel  
vi  
Commercial software 49  
Computer, connecting 7-9

CONDENSED key 16  
COURIER key 15

## D

Default setting report 19-20  
Default settings 24  
Demo page 23  
DRAFT key 15

## E

emulation v, 22, 65  
ENVELOPE key 17  
Envelope mode 17  
Envelopes  
    *See* Paper, envelopes  
Environmental information  
vii  
Epson emulation 22, 49, 71

## F

Factory default settings 24  
15 CPI key 16  
FONT LOCK key 16  
Fonts v, 14-15, 21  
Foreign-language characters  
    *See* Code page, International  
    characters  
Form feed 13  
Form length 22

## G

Graphic dir 22

## H

Hexadecimal dump 23, 64

## I

IBM emulation 22, 49, 74  
Indicator lights 56-58  
International characters 22

## L

Labels 35-37  
LF/FF key 13  
Line feed 13  
Line spacing 22

## M

Macro v, 18  
    loading 24  
    saving 24  
Maintenance 55  
Maintenance self test 24, 63  
Margins 22  
MENU key 18  
MENU slide switch 11  
Menu windows 11

## N

Notes vii  
NLQ dir 22

## O

Off line mode 14  
ON LINE indicator 12  
ON LINE key 13  
ON LINE menu 13-14  
On line mode 14  
Optional accessories 51, 59  
ORATOR key 15

## P

Page skip 22  
Paper  
    bottom feeding 42-43, 54  
    Continuous 32-33, 35

    envelopes 17, 22, 39, 41, 60  
    loading 27-28, 32-33, 35, 39,  
41-43  
    multi-part forms 42-43  
    parking 13-14, 59  
    rear feeding 32-33, 35  
    single sheets 27-28  
    thick 26  
    transparencies 42  
Paper feed knob 3, 45  
Paper guide/paper separator  
27, 33-34  
Paper jams 58  
PAPER OUT indicator  
    *See* POWER/PAPER OUT  
indicator  
Paper parking vi, 37  
Paper select lever 27  
Paper thickness lever 26  
Paper-out sensor 23  
Parallel interface 7-9, 66  
PARK/LOAD key 13-14  
Parts, ordering viii  
Pitch 15  
Power cord 7  
Power requirements 66  
POWER/PAPER OUT  
indicator 13, 29, 56  
PRESTIGE key 15  
PRINT key 18  
Printer drivers 49-50  
PROPORTIONAL key 16  
Push position 25

## Q

QUIET/SAVE key 13

**R**

Rear feeding  
  *See* Paper, rear feeding  
Recycling vii  
Ribbon 21  
  installing 5, 7  
  ordering viii  
Ribbon guide 6  
Ribbon mask 6  
ROMAN key 15  
RS232-C 53

**S**

SANS SERIF key 15  
SAVE key 18  
SCRIPT key 15  
SELECT key 18  
Self test 24, 63-64  
Serial interface 8, 52  
Service centers viii  
Setup 1, 3-5, 7-9  
  software 49-50  
Single sheets  
  *See* Paper, single sheets  
Slashed zero 22  
Slide switches 11  
Software 49-50  
Specifications 66  
Speed v, 65  
STYLE slide switch 11, 15

**T**

Tear bar 22  
Tear off 22  
Tear-off adjustment 23  
Tear-off position 35, 37, 59  
Technical support viii  
10 CPI key 16  
Top cover 4-5

Top-of-form adjustment vi,  
13, 23, 45-47  
Tractor unit 29  
  push position 25  
Troubleshooting  
  alarms 56-58  
  hexadecimal dump 64  
  paper feeding 58-59  
  power 58  
  print quality 61  
  print style 62  
  printer operation 60  
12 CPI key 16

**U**

Unidirectional print 22  
Unpacking 1

**V**

Variable top-of-form  
  *See* Top-of-form adjustment  
VTOP  
  *See* Top-of-form adjustment  
VuePrint menu vii, 17-24, 56

**W**

Warnings vii

**Z**

Zero, slashed 22





## **Citizen Systems America Corporation Limited Warranty**

GSX-190 Printer

### **What is covered and for how long:**

Citizen Systems America Corporation ("Citizen") warrants that the product with which this warranty statement is enclosed is free defects by reason of improper workmanship and/or material and will operate as intended by Citizen for a period of two years. This warranty period commences on the date of original purchase for purposes other than resale and applies only if such original purchase occurs in the United States, Canada, Mexico and in other countries where Citizen provides warranty service.

Despite the above two year warranty term, Citizen warrants consumable items, specifically ribbons, only for the usage described in the user manual which, depending upon product usage, may be significantly shorter than the two year warranty.

### **How to get service under this warranty:**

To obtain service during the warranty period please present your Citizen product, properly packaged in its original container or an equivalent, to Citizen, Citizen's designated agent, or your Citizen Dealer as directed by Citizen. Any postage, insurance and shipping costs incurred in presenting or sending your Citizen product for service are your responsibility.

Your original purchase receipt or other satisfactory proof of the date of the original retail purchase of your Citizen product must be provided to obtain service under this warranty.

### **What Citizen will do to correct problems:**

Citizen will, at its option, repair or replace on an exchange basis the defective product without charge for parts and labor. Citizen may use remanufactured, refurbished, or used parts and components in making warranty repairs.

Should Citizen determine that the product is not defective or is not covered by the warranty or is outside of the warranty term, the product shall be returned to you at your expense without being repaired or replaced.

### **Warranty limitations and other information:**

This warranty applies only if your Citizen product fails to function properly under normal use and within Citizen's specifications described in the User Manual. This warranty does not apply if the Citizen label or logo, or the rating label or serial number, has been removed from your Citizen product, or if, in the sole opinion of Citizen, your Citizen product has been damaged by accident, misuse, neglect, including, but not limited to, improper packing, shipping, modification or servicing by other than Citizen or a Service Center authorized by Citizen to repair this product, or has not been properly maintained or operated as described in the User Manual.

***Neither Citizen nor its affiliates is responsible or liable for any special, incidental or consequential loss, inconvenience or damage, whether direct, incidental, consequential or otherwise, and whether known or should have been known to Citizen, resulting from any breach of warranty, the inability to use the product under any legal theory, including loss of profits, goodwill, damage to or replacement of other equipment and property, and personal injury. These warranties and remedies are the sole and exclusive warranties and remedies in connection with the sale and use of this product. No other warranties, oral or written, express or implied, are given. The duration of any implied warranty of merchantability, fitness for a particular purpose, or otherwise, on your Citizen product shall be limited to the duration of the express warranty set forth above.***

***Some states do not allow the exclusion or limitation of implied warranties or liability for incidental or consequential damages, so the above limitations or exclusions may not apply to you. This warranty gives you specific legal rights, and you may have other rights which vary from state to state.***

No Citizen dealer, agent or employee is authorized to make any modification, extension, change or amendment to this warranty.

### **Who to contact if you have a problem:**

You may REQUEST INFORMATION on how to obtain service under this warranty by contacting the Dealer from whom your Citizen product was purchased, or by contacting Citizen Systems America Corp. at the address printed below. DO NOT SEND PRODUCT(S) TO THIS ADDRESS.

Citizen Systems America Corporation  
363 Van Ness way, Suite 404  
Torrance, CA 90501  
USA

Telephone (310) 781-1460 Fax (310) 781-9152  
<http://www.citizen-systems.com>

## **CITIZEN SYSTEMS AMERICA CORPORATION**

363 Van Ness Way, Suite 404  
Torrance, CA 90501

Tel: (310) 781-1460

Fax: (310) 781-9152

<http://www.citizen-systems.com>

Part No. AK74984-51F

ABE-0606

Printed in China