User's Manual (Model B and C)

iSAPPOS 9/12 Stand



iSAPPOS

Getting ready with the stand



Package contents

System Overview

Getting started

Package Contents

Model B

- Aluminum base plate
- Aluminum Stand body
- Jacket for iPad ¹
- 5V/4A 20W power adapter
- 3 x RJ-45 COM port cables
- 1 x Micro-USB cable (for data-syncing)
- 2 x Screws for the Stand jacket
- 2 x thumb screws for the Stand base plate
- 2 x coin screws for the rear cover
- Quick user guide

1. iPad not included. Compatible only with iPad Air 2, 9.7" and 12.9" iPad Pro.

Model C

- Aluminum base plate
- Aluminum Stand body
- Jacket for iPad ¹
- 19V/4.7A 90W power adapter
- 2 x RJ-45 COM port cables
- 1 x RJ-11 cable for cash drawer
- 1 x Micro-USB cable (for data-syncing)
- 2 x Screws for the Stand jacket
- 2 x thumb screws for the Stand base plate
- 2 x coin screws for the rear cover
- Quick user guide

1. iPad not included. Compatible only with iPad Air 2, 9.7" and 12.9" iPad Pro.

System Overview

The Jacket

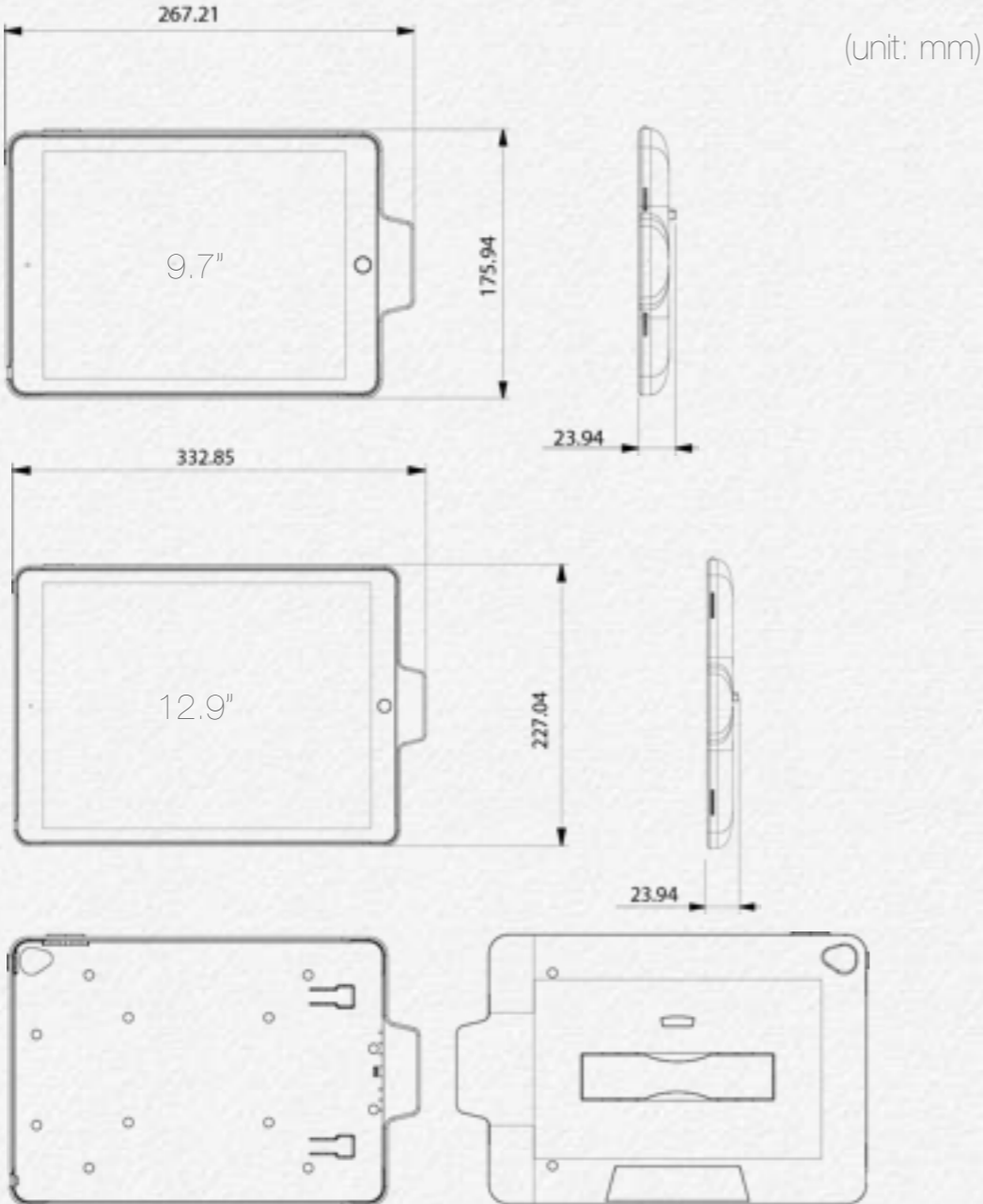

The Stand

Model B

(unit: mm)

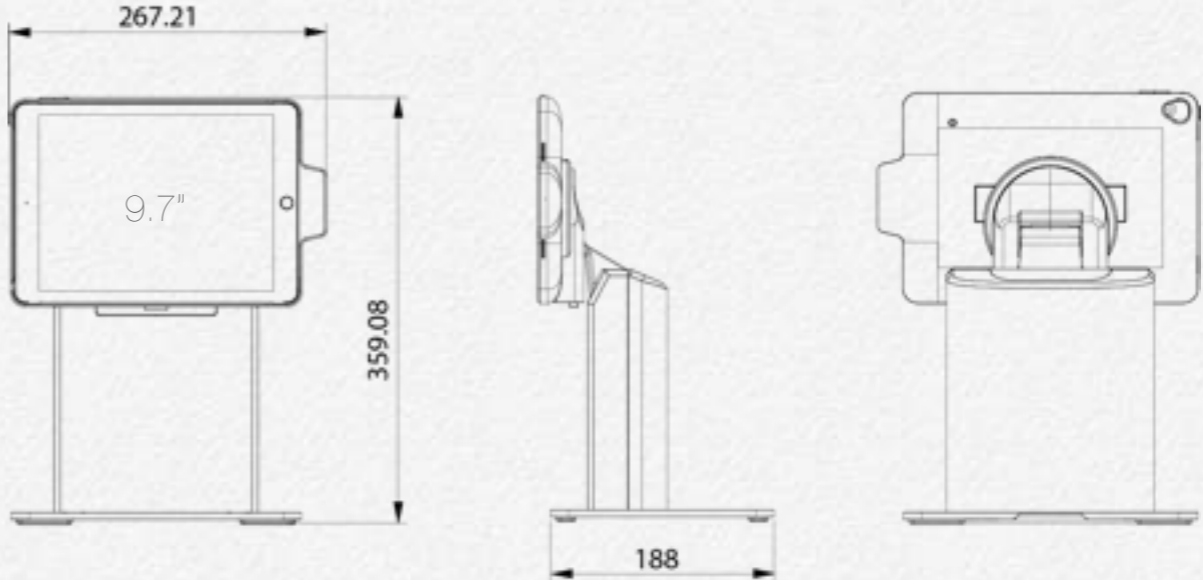

Model B

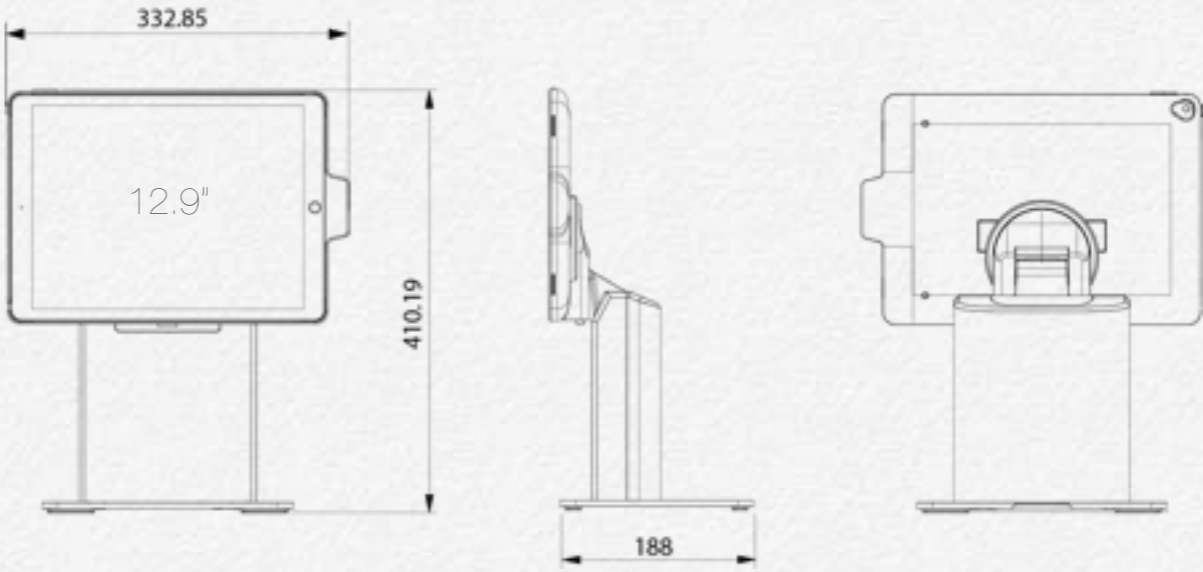

Model C

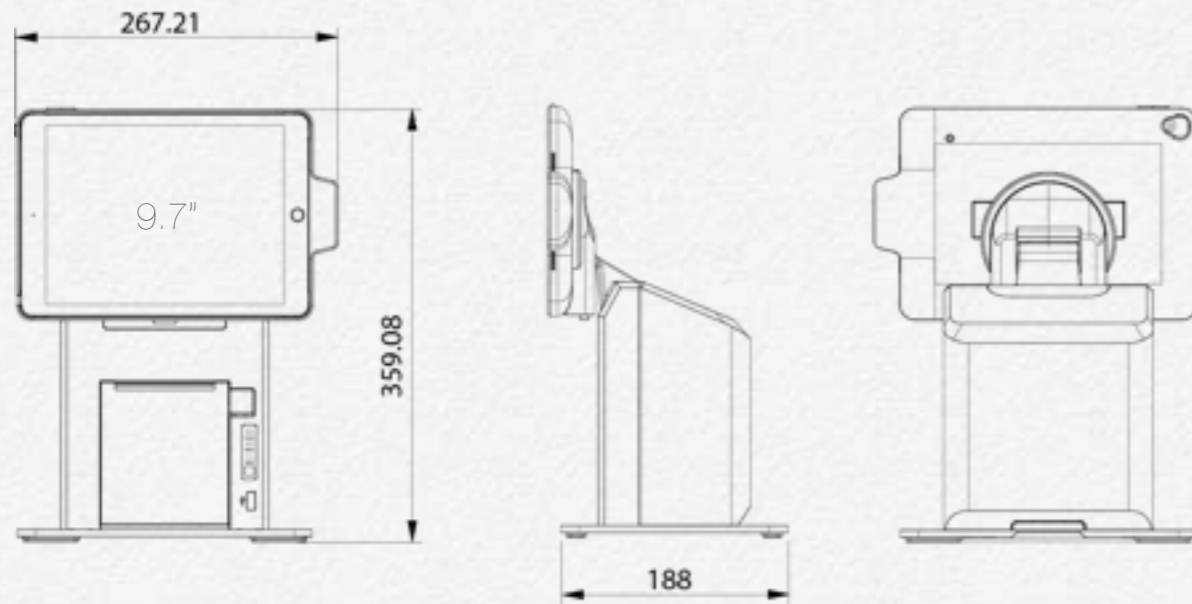

Model C

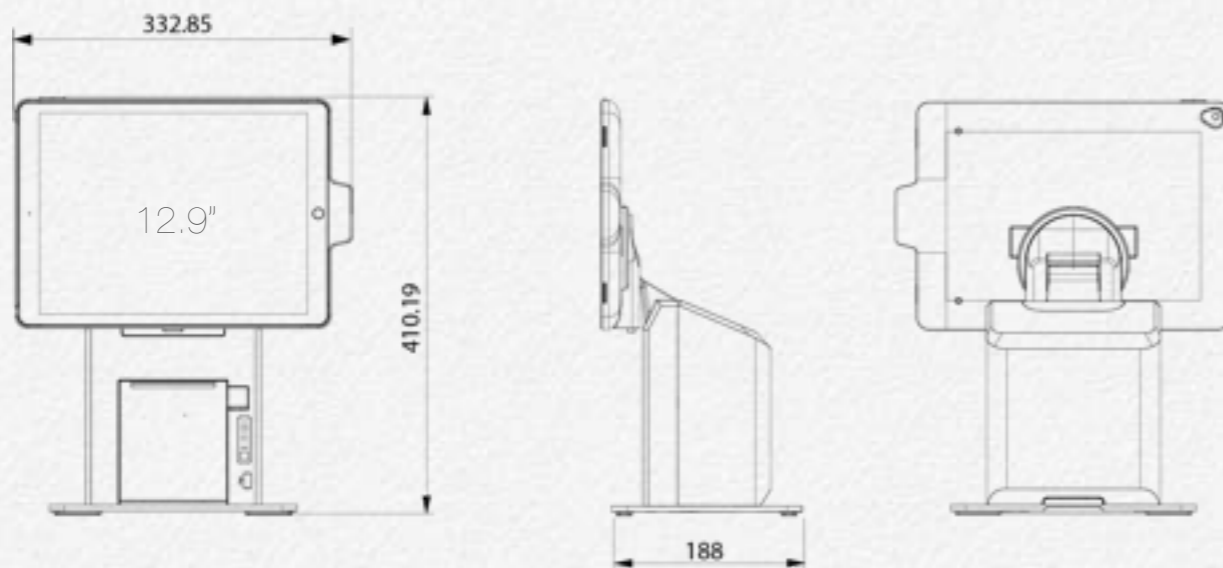

I/O Ports

Model B

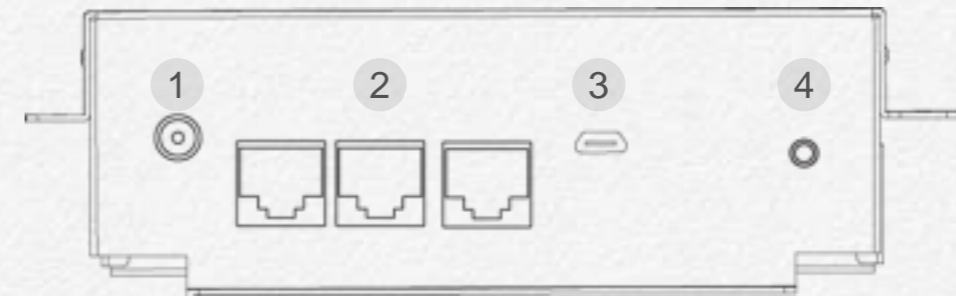

- 1 Power connector
- 2 RJ-45 to COM ports
- 3 Micro-USB port (iPad data syncing)
- 4 Bluetooth Pair button

Model C



- 1 RJ-11 cash drawer port
- 2 RJ-45 to COM ports
- 3 Power connector
- 4 Micro-USB port (iPad data syncing)
- 5 USB port (peripheral charging)
- 6 Bluetooth Pair button

LEDs

Model B/C

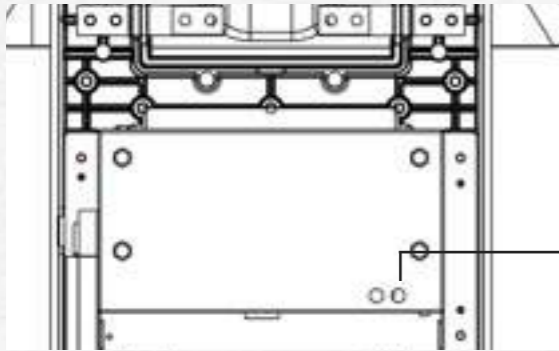

1

Pairing LED:
Blinking green: Stand
Bluetooth pairing mode on

1

(rear view of the Stand with rear plastic cover removed)

Model C

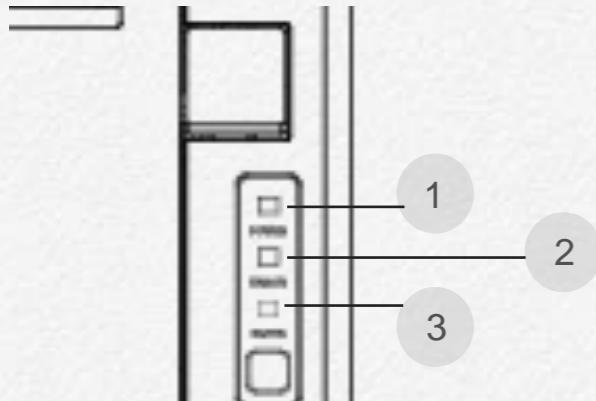

1

Power LED:
Solid green System on
Off: System off

2

Error LED:
Solid red System error
Off: System normal

1

2

3

3

Paper LED:
Solid green Printer normal
Solid red: printer error

Getting started

Getting started

Assemble iPad and the Stand

- Tools needed - Phillips(+) #0 Screwdriver



- Assemble the stand

1. Secure the base plate and Stand body with M4 thumb screws (x4) found in the accessory box.

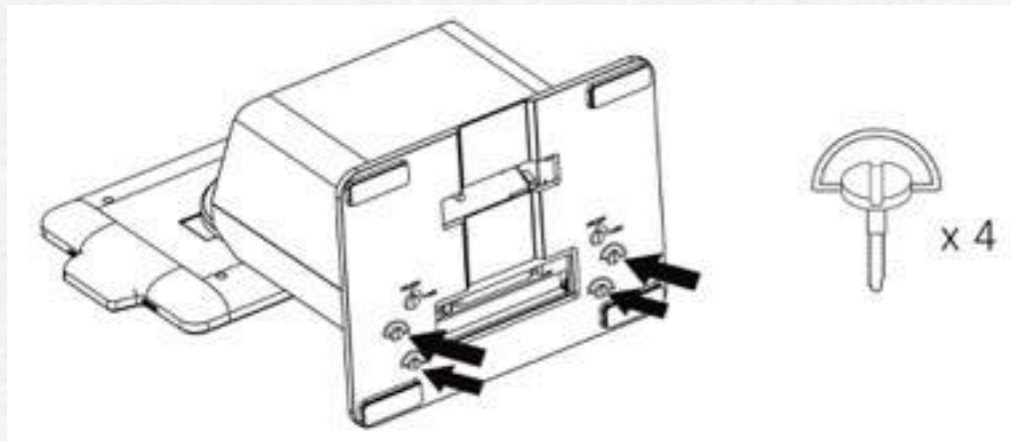

2. Connect the power adapter for charging.

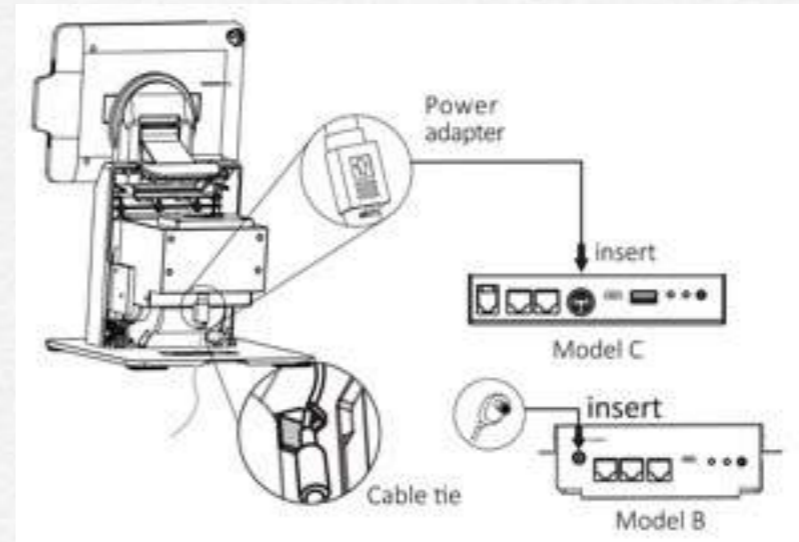

** Please make sure the power adapter is plugged in before connecting the 3rd party peripherals*

3. Place the back cover to the back of the stand. Secure the back cover the base plate using the coin screws (x2) found in the accessory box. Tighten them with a coin.

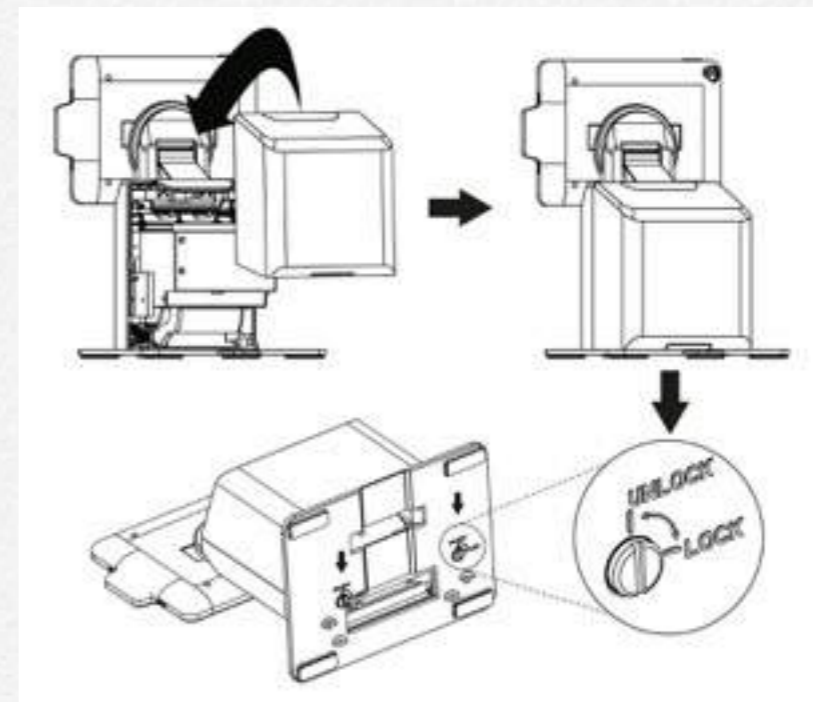

4. Insert the iPad to the jacket
 - ➔ Slide open the jacket

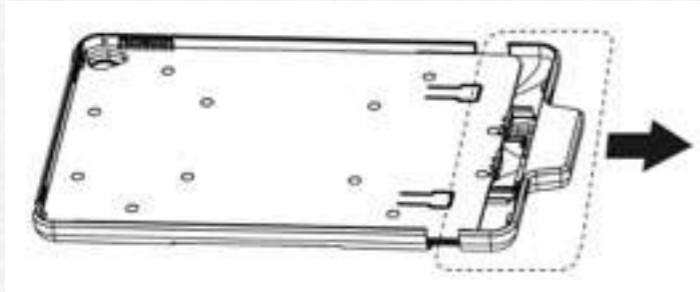

- ➔ Insert and align iPad with the jacket (It's normal to see the side with the home bottom is higher than the other side)

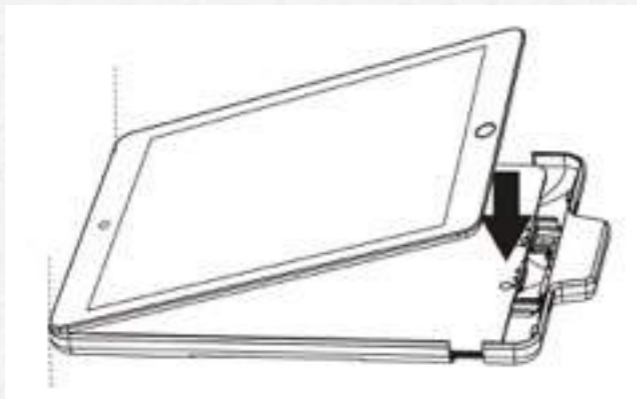

- ➔ Slide close the jacket gently and slowly. While sliding close the jacket, press down both corners of the iPad like indicated in the picture and make sure it's aligned with the jacket.

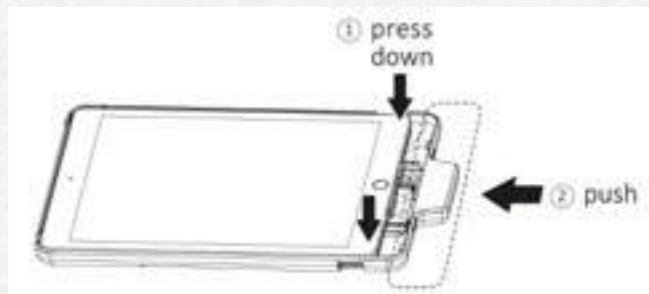

- ➔ Remove the paddings of the indicated screw holes. Secure the iPad and the jacket with Phillips(+) #0 Screwdriver and M2 screws (x2) found in the accessory box. Place the paddings to cover the indicated screw holes.



5. Place the jacket onto the Stand's dock. (make sure the lock-unlock switch is in the unlock position)

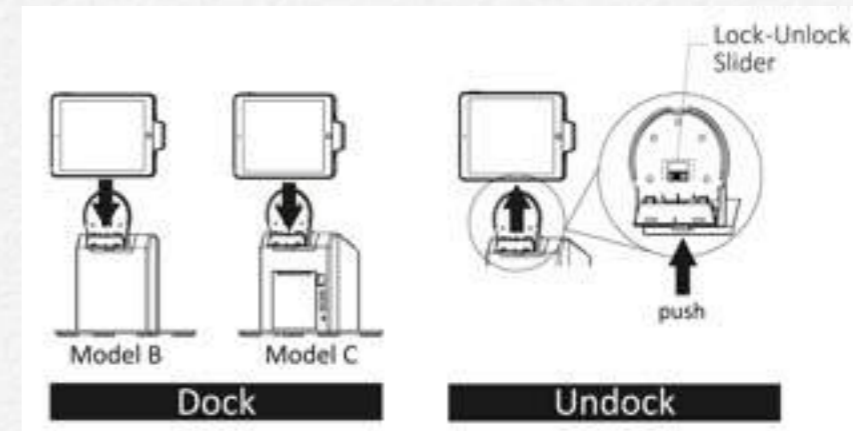

* Undock: Push the button at the bottom of the cradle and lift up the jacket to detach it from the Stand.

Unlock Jacket from the Stand Manually

If the jacket is placed on the Stand while the Lock-Unlock slider on the cradle is in "Lock" position, you can manually override the switch and unlock the jacket from the Stand by using a paperclip and push up the button hidden at the bottom of the cradle. Lift up the jacket while the button is pushed up to detach it from the Stand.

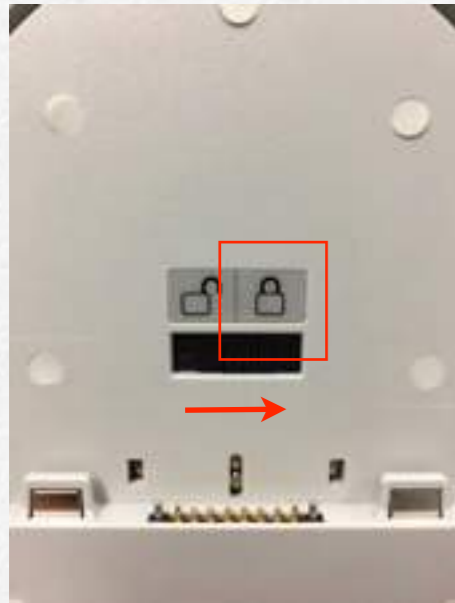

When locked



**Override
mechanism to
unlock**

Install app (Model B and C only)



iSATouch Unlock



SteakHouse
(demo)

** The SteakHouse app is only an app to demonstrate the functions of the Stand. It is not suitable to be used in the actual business environment.*

Product Warranty Registration

Register your Stand for warranty by visiting our customer portal. Simply sign up for an account and enter your Stand's serial number to complete the warranty registration process.



Running and using the app

2

Turn on Bluetooth

iSATouch Unlock App

SteakHouse App

Turn on Bluetooth

Pairing with the Stand (For Model B and C only)

The app will essentially help you set up the Stand with your iPad. As the Stand communicates with your iPad through Bluetooth, please make sure Bluetooth is enabled on your iPad by before launching the app. You can enable Bluetooth by going to **Settings** → **Bluetooth**.



After you have Bluetooth enabled, remove the back cover from the Stand and locate the *pair* button in the back. Press the button to initiate bluetooth connection between the Stand and your iPad. The *Pairing* LED should start blinking.

Model B

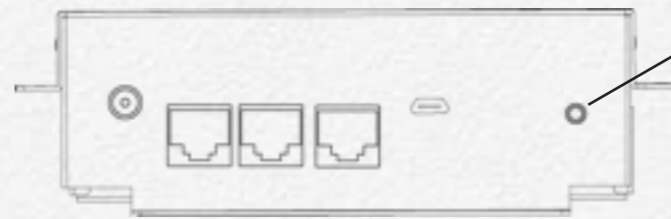

- 1 Press pairing button
- 2 LED blink in green



Model C



- 1 Press pairing button
- 2 LED blink in green

iSATouch Unlock App

About the app

The app provides a simple function that allows you to connect to your stand and unlock the jacket from it by using Apple's TouchID.

Launching the app (For Model B and C only)

After the app is downloaded and installed, you should be able to locate it on the home screen. Simply tap on it to launch the app.

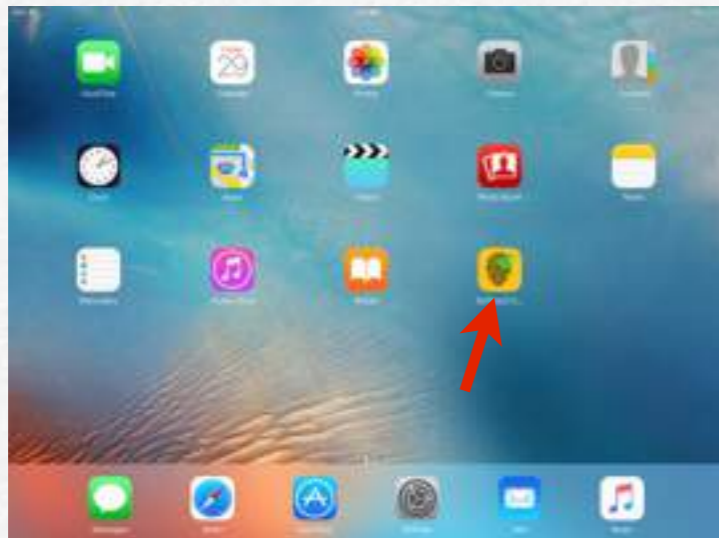

Connect the Stand

Opening the app will start scanning a nearby Stand immediately. Push the pair button in the back of the Stand will start broadcasting itself to the app.

Once the Stand is found, it will be displayed like shown in the screenshot below. Simply tap the icon to connect to the stand.



* If your Stand is not found in the app, check the pairing LED in the back of the Stand and make sure it is blinking (in pairing mode). If not, press the pair button to start pairing again.

* If you have multiple Stands nearby, you can easily locate the Stand you would like to connect to by looking up the last four digit of the MAC address that is on the label in the back of your Stand. Match those numbers with the one shown in the app.

When you pair your iPad with the Stand for the first time, you will be prompted to enter passcode, simply enter **“2234”** and tap “Pair” to finish the pairing process.



Once you are successfully connected to the Stand, you should be directed to another page of the app where you can access the unlock function.



* If a previously connected Stand is disconnected due to reasons such as out of range or powered off, the icon will be displayed in a semi-transparent color illustrating an inaccessible Stand.



Tapping the icon will unlock the jacket from the Stand through Apple's TouchID function in your iPad. The jacket should be unlocked once the fingerprint matches the one you set up in your iPad.



* In order for this function to work, please first set up fingerprint for the TouchID function in your iPad by going to **Settings > Touch ID & Passcode**

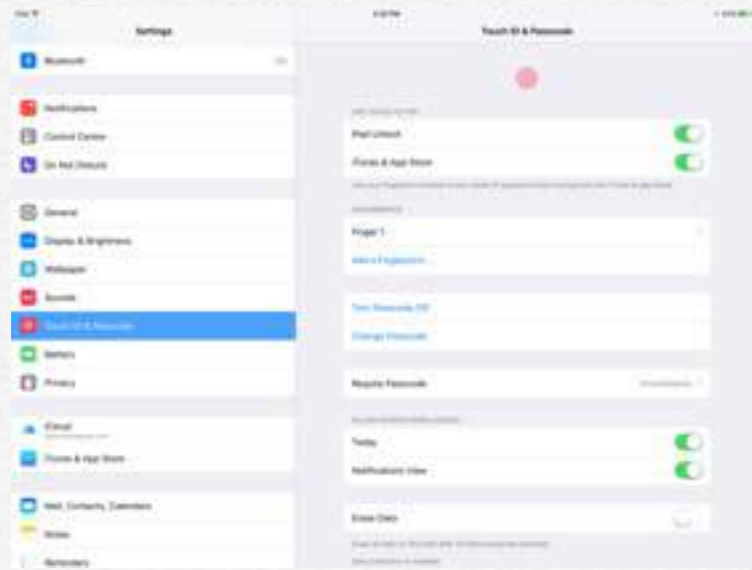

You will have a 10 second window to remove the jacket from the stand before it is locked again. During this period of time, the unlock button will be disabled.



Using iOS Today's Widget to unlock the jacket

After the app is installed, it also installs an app widget which can be accessed from iOS Today's Widget menu. The advantage of providing an app widget is that the unlock function can be easily accessed anytime with a swipe down on the screen regardless what app you are currently using.

To enable the widget, pull down anywhere from the top of the iPad screen to access Today's Widget menu.

You will need to enable the app widget first. To do so, tap on the "Edit" button to add the app widget to the menu.

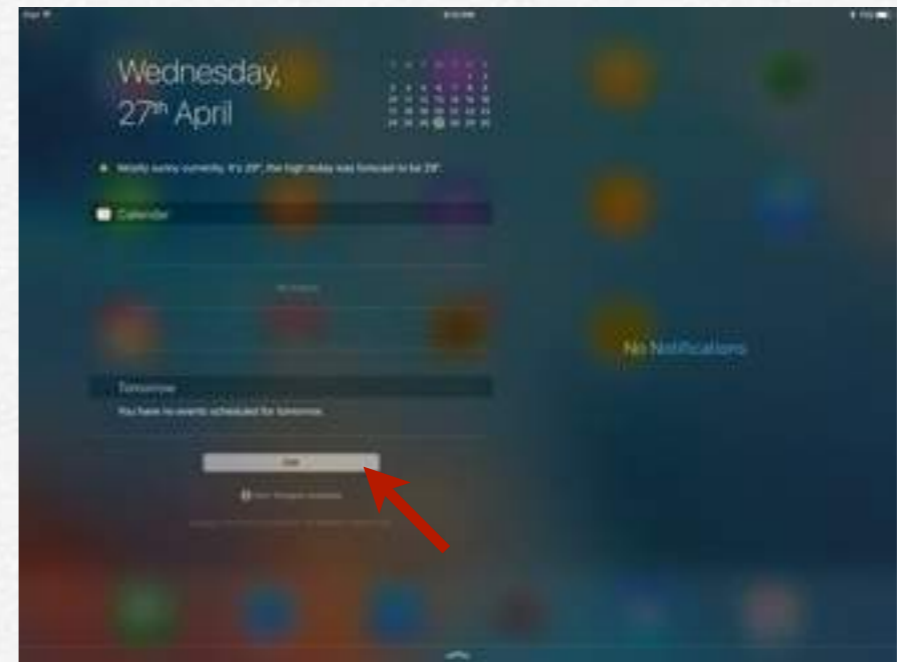

You should see the iSATouch Unlock app widget from the list menu like shown below. Tap on the green "+" button to add it to the Today's widget menu.

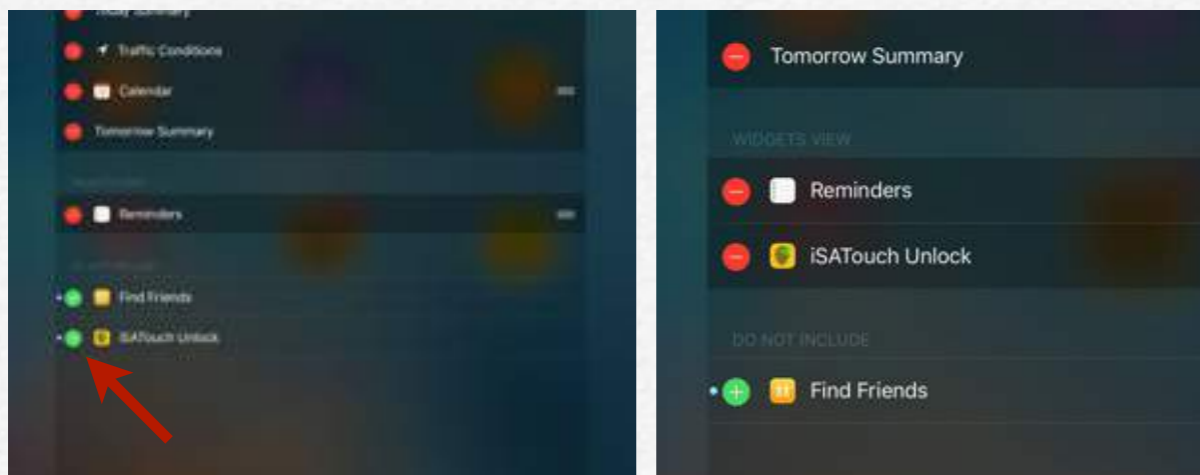

Tap "Done" to finish.

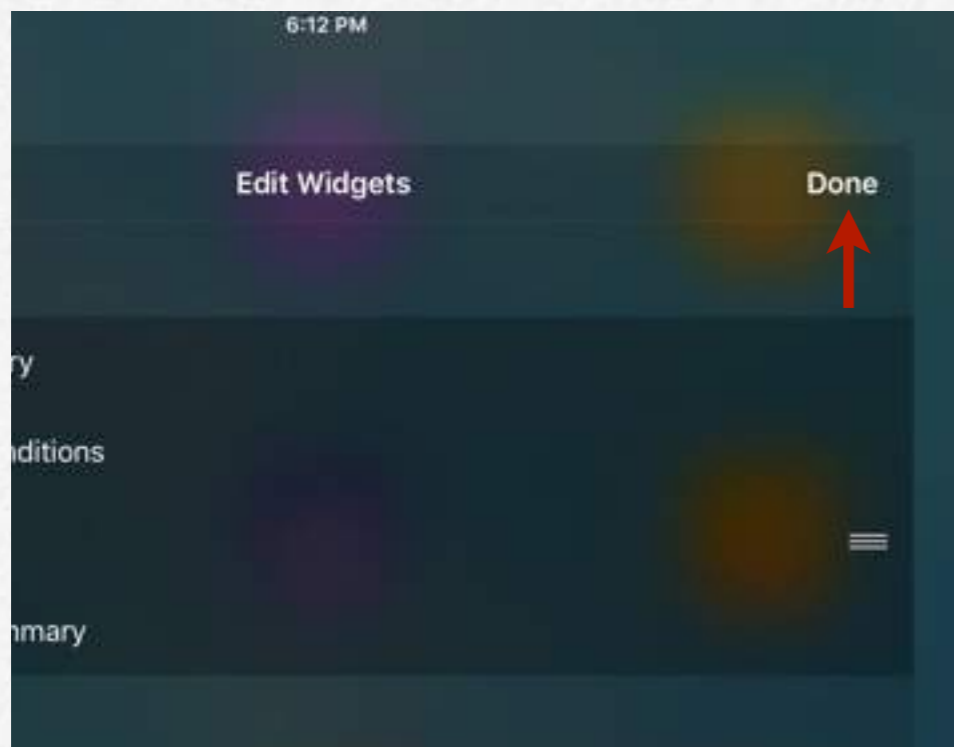

You can now access the app widget in iOS Today's Widget menu. Tapping on the icon will allow you to unlock the jacket without leaving or closing the app you are currently using.

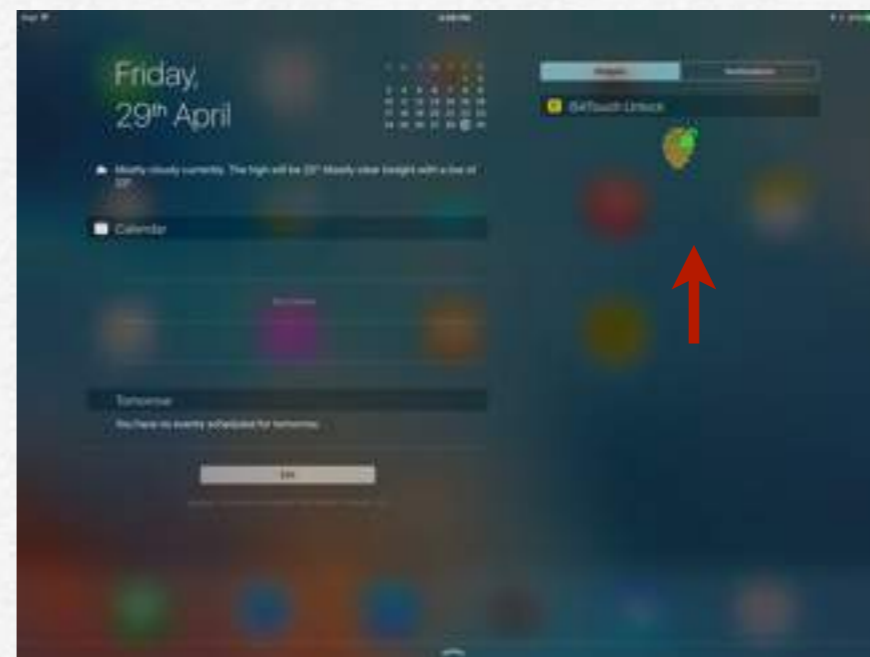

**If your Stand is disconnected when you are unlocking the jacket from the Today's Widget menu, the iSATouch Unlock main app will be launched instead so you can pair with the Stand again.*

SteakHouse App

About the app

The app provides users the ability to connect and configure the Stand as well as accessing its hardware functions in a form of a simple POS (Point of Sales) app.

Launching the app (For Model B and C only)

After the app is downloaded and installed, you should be able to locate it on the home screen. Simply tap on it to launch the app.

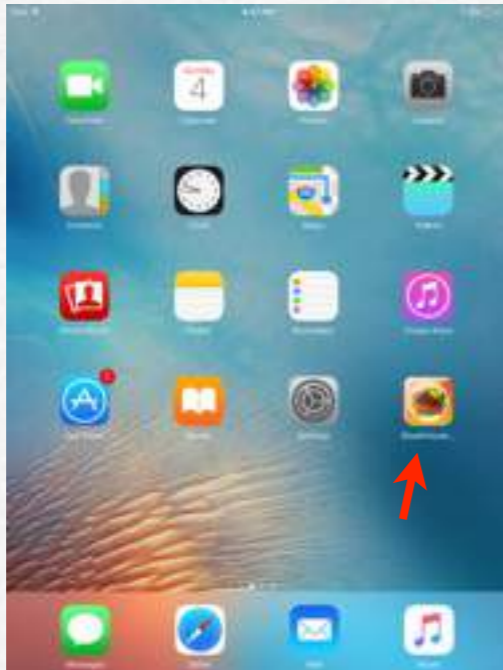

Log in the app

You will be prompted to log in after the app is launched.



If you have TouchID configured on your iPad, simply log in with TouchID.



If TouchID is not yet configured, tap on the "Enter Password" option to log in by entering the password manually.



When prompted, enter the password **"1234"** to log in.



Connect the Stand

To connect the Stand with the app, tap on "BLE Config" in the lower-left hand corner of the app.



The app will start searching for Stands nearby. Press the "Pair" button in the back of the Stand for the one you wish to connect with the app. Tap on the one from the list to connect to the Stand.

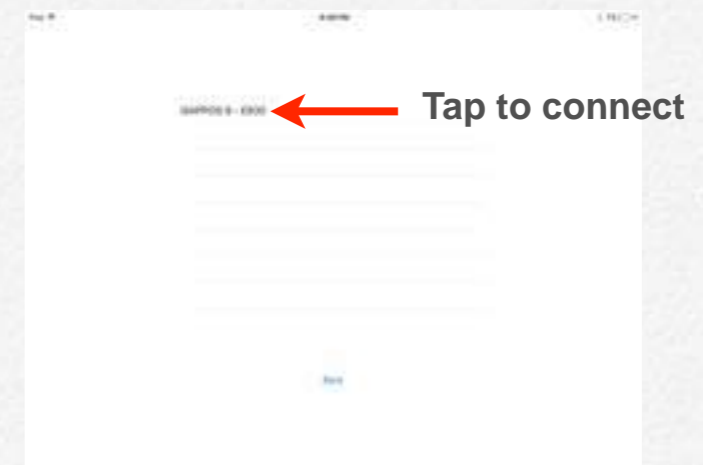

* if you are prompted for password, enter **"2234"** to connect to the Stand.

If you have more than one Stands powered on nearby, use the ID number from the back of the Stand (with rear plastic cover removed) and match it with the one from the list shown in the previous step to make sure you are connecting to the desired Stands.



Once connected, you will be directed back to the main page upon a successful connection. The connection status with the Stand should now be "**Connected**" in the lower-left hand corner of the app.



Configuring the COM ports for peripherals

There are three COM ports in the model B and two COM ports in the model C in which you can connect compatible peripherals to.

Change settings in the "COM Config" page according to the peripheral that is connected to the Stand through the COM interface.



- * Do not change settings on Printer Port 3 when using the app with a model C Stand. The built-in printer in model C is designed to use port 3 at all time.
- * To change value of any field, tap on the blue text in that field to do so.
- * You shouldn't need to change any settings when using a compatible peripheral. Simply connect the peripheral to the Stand and make sure the Stand is connected to the app.

Connect and configure compatible printer

You can connect an external compatible printer through the COM port in the Stand. Change the "Printer Model" in the "COM Config" page that matches the one that is connected to the Stand.

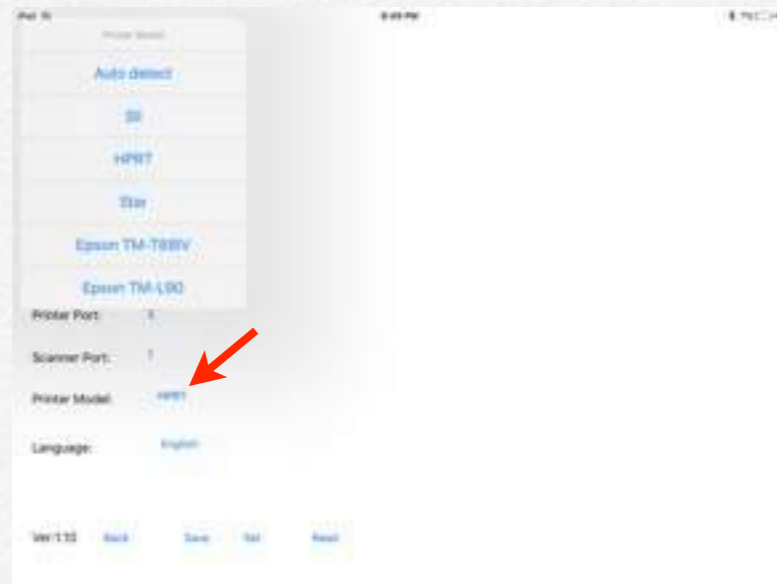

- * HPRT is the default printer model as it is the one that is built into the model C Stand.
- * You can alternatively change it "Auto detect" for easier configuration when connecting to an external printer.
- * The Stand supports COM interface printer from Star as well as Epson (only the models listed in the above screenshots).

Connect and configure compatible scanner

The Stand supports COM interface scanner from Opticon. Be sure to select the correct port number based on which port the scanner is being connected to.

For any changes to take effect, tap "Set" first and tap "Save" to save the new settings.

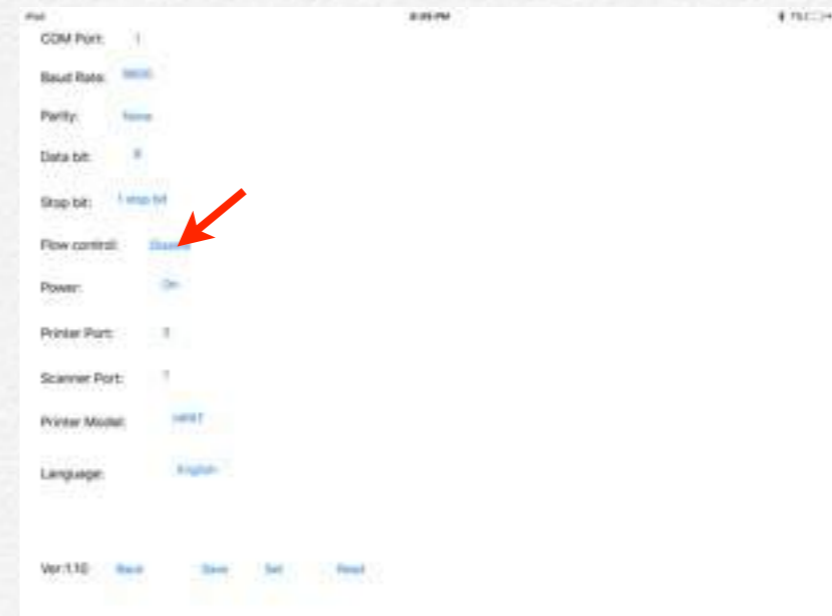

- * Should you have interest to purchase Opticon scanners, please contact us at isappos@isappos.com

Print receipts with the app

To print receipts with the app, add items from the menu first. Added items should be shown in the list on the left.



Tap on the "Cash" button should print out the receipt with items added.



Below screen will be shown after tapping on the "Cash" button. Simply tap "Back" to go back to the main screen.



Unlock the jacket from the Stand

If the jacket is placed and locked on the Stand, you can unlock the jacket by using the "Undock" function in the app.

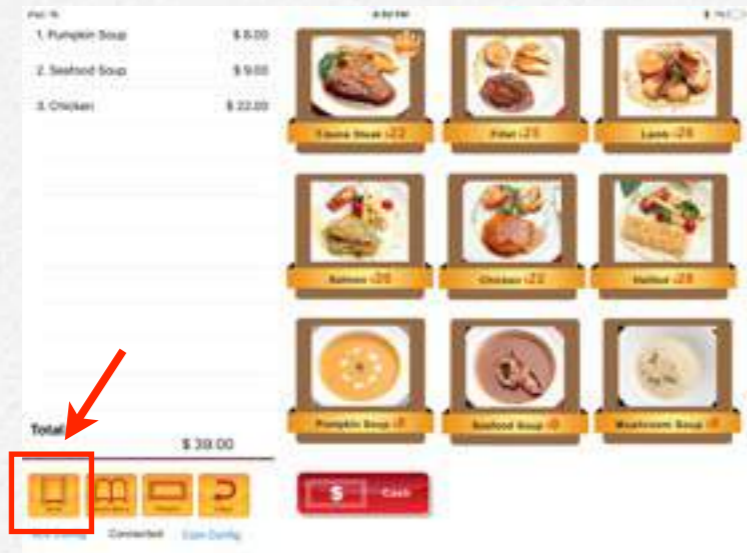

You will be prompted for authentication using the TouchID to unlock the jacket.

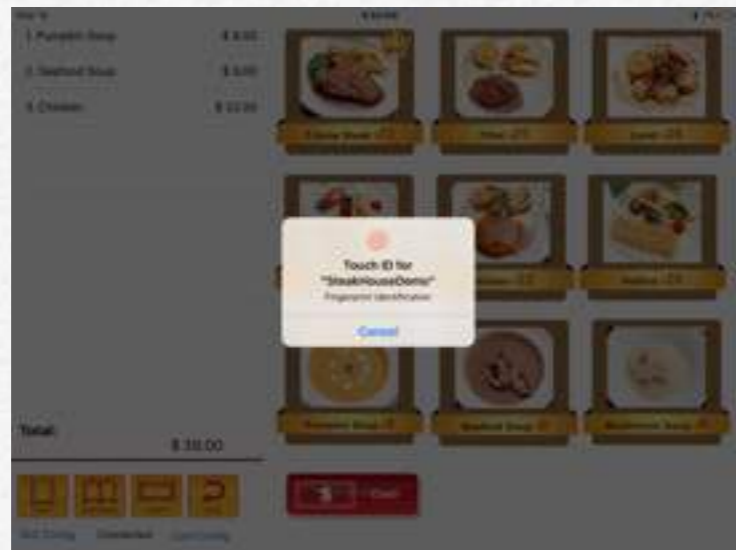

The Stand only connects to one app at a time

Please note the Stand can only remain connection with one app at a time. The last app that Stand connects to will disconnect the Stand from the previously connected app.

Regulatory Information



Regulatory Information

Safety Caution

Legislation and WEEE
Symbol

Safety Instruction

Environmental

Regulatory Information

Caution: Do not remove the plug and connect it to a power outlet by itself; always attach the plug to the power adapter first before connecting it to a power outlet.

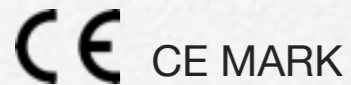

This device complies with the requirements of the EEC directive 2004/108/EC with regard to “Electromagnetic compatibility” and 2006/95/EC “Low Voltage Directive”.



This device complies with part 15 of the FCC rules. Operation is subject to the following two conditions:

- (1) This device may not cause harmful interference.
- (2) This device must accept any interference received, including interference that may cause undesired operation.

Safety Caution

Note: To comply with IEC60950-1 Clause 2.5 (limited power sources, L.P.S) related legislation, peripherals shall be 4.7.3.2 “Materials for re enclosure” compliant.

4.7.3.2 Materials for re enclosures
For MOVABLE EQUIPMENT having a total mass not exceeding 18kg.the material of a FIRE ENCLOSURE, in the thinnest significant wall thickness used, shall be of V-1 CLASS MATERIAL or shall pass the test of Clause A.2.
For MOVABLE EQUIPMENT having a total mass exceeding 18kg and for all STATIONARY EQUIPMENT, the material of a FIRE ENCLOSURE, in the thinnest significant wall thickness used, shall be of 5VB CLASS MATERIAL or shall pass the test of Clause A.1

LEGISLATION AND WEEE SYMBOL

2012/19/EU Waste Electrical and Electronic Equipment Directive on the treatment, collection, recycling and disposal of electric and electronic devices and their components.



The crossed dust bin symbol on the device means that it should not be disposed of with other household wastes at the end of its working life. Instead, the device should be taken to the waste collection centers for activation of the treatment, collection, recycling and disposal procedure.

To prevent possible harm to the environment or human health from uncontrolled waste disposal, please separate this from other types of wastes and recycle it responsibly to promote the sustainable reuse of material resources.

Household users should contact either the retailer where they purchased this product, or their local government of CE, for details of where and how they can take this item for environmentally safe recycling.

Business users should contact their supplier and check the terms and conditions of the purchase contract.

This product should not be mixed with other commercial wastes for disposal.

Safety Instructions

Please adhere to the following safety guidelines to help ensure your own personal safety and protect your system from potential damage. Any acts taken that are inconsistent with ordinary use of the product, including improper testing, etc., and those not expressly approved by iSAPPOS may result in the loss of product warranty.

Unless expressly approved by an authorized representative of iSAPPOS in writing, you may not and may not permit others to:

- Disassemble or reverse engineer the device or attempt to derive source code (underlying ideas, algorithms, or structure) from the device or from any other information provided by iSAPPOS, except to the extent that this restriction is expressly prohibited by local law.
- Modify or alter the device.
- Remove from the device any product identification or other notices, including

copyright notices and patent markings, if any. To reduce the risk of bodily injury, electrical shock, fire, and damage to the device and other equipment, observe the following precautions:

Power Sources

- Observe and follow service markings.
- Do not push any objects into the openings of your device unless consistent with the authorized operation of the device. Doing so can cause a re or an electrical shock by shorting out interior components.
- The powering of this device must adhere to the power specifications indicated for this product.
- Do not overload wall outlets and/or extension cords as this will increase the risk of re or electrical shock.
- Do not rest anything on the power cord or on the device (unless the device is made and expressly approved as suitable for stacking).

-
- Position system cables and power cables carefully; route cables so that they cannot be stepped on or tripped over. Be sure that nothing rests on any cables.
 - Operate the device only from the type of external power source indicated on the electrical ratings label.
 - To help avoid damaging your device, be sure the voltage selection switch (if provided) on the power supply is set to match the power available at your location.
 - Also be sure that attached devices are electrically rated to operate with the power available in your location.
 - Use only approved power cable(s). If you have not been provided a power cable for your device or for any AC-powered option intended for your device, purchase a power cable that is approved for use in your country and is suitable for use with your device. The power cable must be rated for the device and for the voltage and current

marked on the device's electrical ratings label. The voltage and current rating of the cable should be greater than the ratings marked on the device.

- To help prevent an electrical shock, plug the device and peripheral power cables into properly grounded electrical outlets. These cables are equipped with three-prong plugs to help ensure proper grounding. Do not use adapter plugs or remove the grounding prong from a cable. If you must use an extension cable, use a 3-wire cable with properly grounded plugs.
- Observe extension cable and power strip ratings. Ensure that the total ampere rating of all products plugged into the extension cable or power strip does not exceed 80 percent of the ampere ratings limit for the extension cable or power strip.
- To help protect your device from sudden, transient increases and decreases in electrical power, use a

surge suppressor, line conditioner, or uninterruptible power supply (UPS).

- Do not modify power cables or plugs. Consult a licensed electrician or your power company for site modifications. Always follow your local/national wiring rules.
- When connecting or disconnecting power to hot-pluggable power supplies, if offered with your device, observe the following guidelines.
- Install the power supply before connecting the power cable to the power supply.
- Unplug the power cable before removing the power supply.
- If the system has multiple sources of power, disconnect power from the device by unplugging all power cables from the power supplies.

Servicing/Disassembling

- Do not service any product except as expressly set forth in your system documentation.
- Opening or removing covers that are marked with the triangular symbol with a lightning bolt may expose you to an electrical shock. Only a trained service technician should service components inside these compartments.
- To reduce the risk of electrical shock, never disassemble this device. None of its internal parts are user-replaceable; therefore, there is no reason to access the interior.
- Do not spill food or liquids on your system components, and never operate the device in a wet environment. If the device gets wet, see the appropriate section in your troubleshooting guide or contact your trained service provider.
- Use the device only with approved equipment.

- Move products with care; ensure that all casters and/or stabilizers are firmly connected to the system. Avoid sudden stops and uneven surfaces.

Environment

- Do not use this device near water (e.g. near a bathtub, sink, laundry tub, in a wet basement or near a swimming pool).
- Do not use this device in areas with high humidity.
- This device must not be subjected to water or condensation.
- Keep your device away from radiators and heat sources. Also, do not block cooling vents.

Cleaning

- Always unplug the power before cleaning this device.
- Do not use liquid or aerosol cleaners of any kind. Use only compressed air that is recommended for electronic devices.

- Use a dry cloth for cleaning.

Protecting Against Electrostatic Discharge

Static electricity can harm delicate components inside your system. To prevent static damage, discharge static electricity from your body before you touch any of the electronic components, such as the microprocessor. You can do so by periodically touching an unpainted metal surface on the chassis.

You can also take the following steps to help prevent damage from electrostatic discharge (ESD):

1. When unpacking a static-sensitive component from its shipping carton, do not remove the component from the antistatic packing material until you are ready to install the component in your system. Just before unwrapping the antistatic packaging, be sure to discharge static electricity from your body.
2. When transporting a sensitive component, first place it in an antistatic container or packaging.

3. Handle all sensitive components in a static-safe area. If possible, use antistatic floor pads, workbench pads, and an antistatic grounding strap.

iSAPPOS © COPYRIGHT 2017. ALL RIGHTS RESERVED.

Apple iPhone and iPad are registered trademarks of Apple, Inc. and are not included. They serve as a reference only and does not imply any affiliation with or endorsement by Apple.

UM00BC0EN0802171