

Spectrum Air™

IP 65 Rated Dual Headed Magnetic Stripe Insert Reader

Built for Protection

The Spectrum Air Dual Headed Magnetic Stripe Insert Reader has been developed for applications requiring (IP 65) sealed readers that are designed to withstand the rigors of an outdoor environment. The Spectrum Air's superior sealed chassis design prevents the ingress of water, vapor and other contaminants into the main terminal enclosure.

Class Leading Durability and Reliability

The Spectrum Air's unique chassis design greatly reduces the possibility of leaks developing over the life of the product. It's dual heads are embedded with a flex circuit, which is intrinsically easier to seal than heads with wires. The Spectrum Air card seated switch is magnetically actuated and immune to contamination and corrosion. It utilizes ID TECH's superior decoding electronics for optimum reading reliability.

Encryption Security

The Spectrum Air is designed with ID TECH's secure electronics providing either TDES or AES encryption and DUKPT key management to provide the data security from the point of entry.

The Spectrum Air is ideal for gas pumps and outdoor kiosk applications. Cards are read on both insertion and/or withdrawal for superior reading reliability. Multiple interfaces allow the reader to be configured for "drop in replacement" applications when required.

Features and Benefits

- Dual Headed Magnetic Stripe Insert Reader
- Reads up to three tracks of card data
- Interface: TTL, RS232, USB-KB, USB-HID
- IP 65 Rated
- Sealed bezel and chassis
- Supports TDES or AES encryption with DUKPT key management
- Ideal for gas pumps, vending and outdoor kiosk applications
- 1 year warranty



IDTECH®
Value through Innovation

Spectrum Air™ Specifications SPTS-2XX Series

Electrical

Power Requirements (RS-232):	+5 VDC/55mA (power adapter regulated 5 VDC/250mA or equivalent)
Power Requirements (USB):	+5 VDC/55mA power supplied by the host computer
Operating Current:	55 mA maximum for three tracks of magnetic data
Chassis Ground:	Connected to GND and magnetic head case
Interfaces:	RS232 Serial, USB-CDC (virtual COM), USB-HID, USB-HID-KB, and Keyboard Wedge (PS/2)



Environmental

Operating Temperature:	-20°C to 70°C, non-freezing on mechanical components
Storage Temperature:	-40°C to 70°C
Operating Humidity:	10% to 90% non-condensing
Storage Humidity:	10% to 90% non-condensing

Reliability

Magnetic Head Life:	1,000,000 cycles minimum*
Chassis and Bezel:	1,000,000 card cycles minimum*
Warranty:	One year, parts and labor

**All wear reliability numbers are based on operation in a benign environment*

Mechanical

Physical Dimensions:	With bezel size 120mm x 92mm x 48mm (L x W x H)
General Construction:	PC UL 94V-0 plastic chassis
Media Thickness:	0.76mm (tolerance +/- 0.08mm)
Media Formats:	ISO 7810 ID-1 card, ISO 7811, AAMVA Driver License format
Color:	Black
Seal Rating:	IP 65

Footprint:

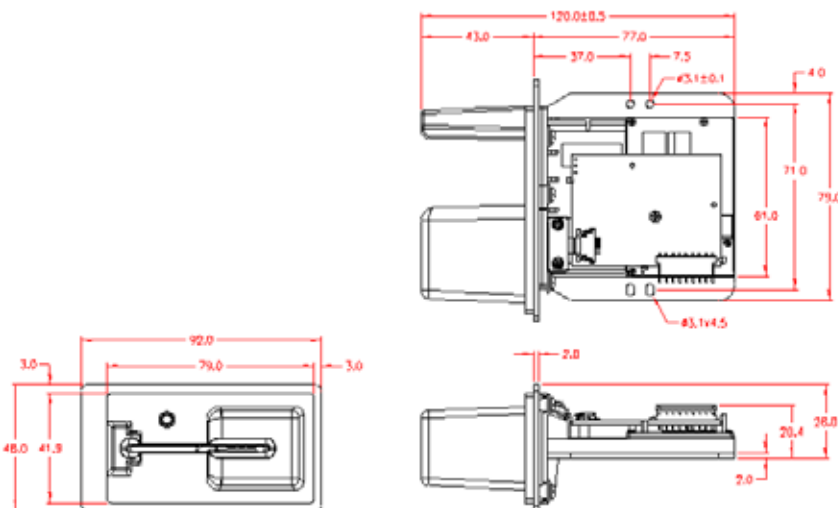

IDTECH®

Value through Innovation

Corporate Headquarters:

10721 Walker Street, Cypress, California 90630
www.idtechproducts.com
(714) 761-6368 sales@idtechproducts.com

International Sales Office for Canada & South America:

+450 465 5261 (Canada) robertop@idtechproducts.com

European Sales Offices:

+49(0) 8851 6159900 (Germany)
emea@idtechproducts.com

ISO 9001 Certified