

WindFall®

# KIOSK

Floor Stand

Place information and interactivity anywhere—beautifully. Far too often tablet kiosks are obtrusive, ugly, or made with consumer-grade materials. WindFall Kiosk bucks this unfortunate trend. Fabricated completely of fully-welded heavy steel yet featuring a sleek, unobtrusive design, WindFall Kiosk complements any professional environment. But don't let its visual simplicity fool you—it's packed

Designed carefully to compliment its environment and to provide an unobstructed view of the objects behind, WindFall Kiosk will look good anywhere. Its tapered, reaching neck invites interaction while adding a sculptural element to the room.

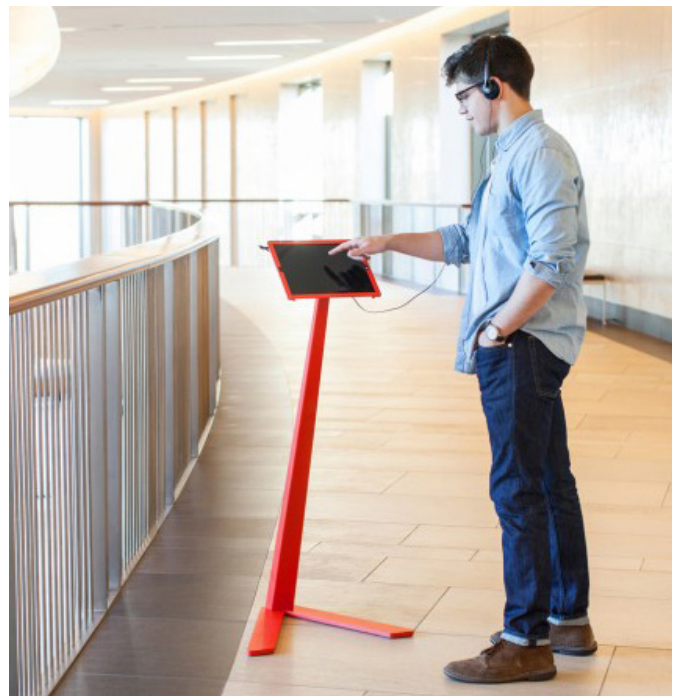

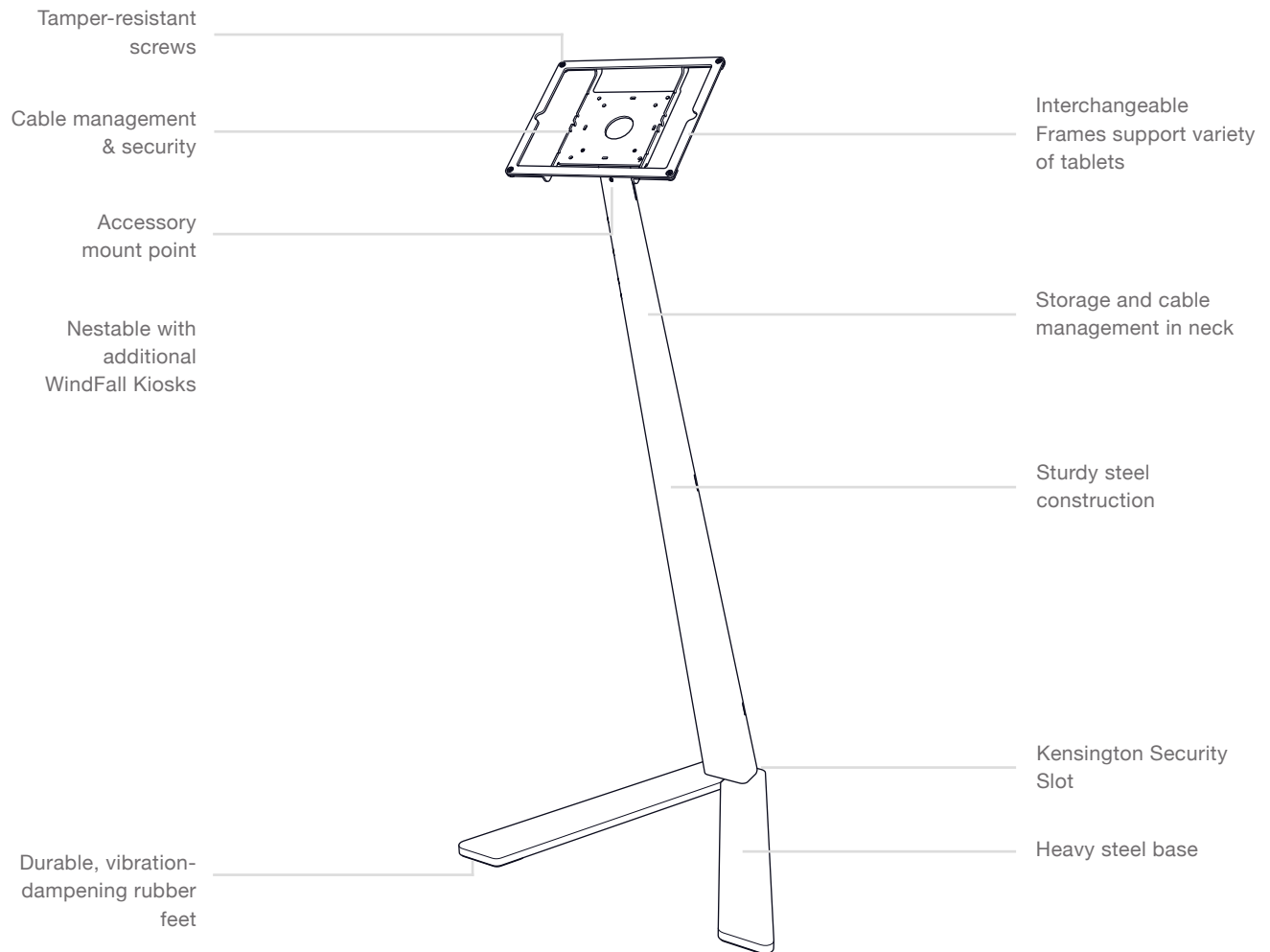

### Specifications

<b>Price</b>	\$499	<b>Weight</b>	28 pounds
<b>SKU</b>	H252	<b>Angle</b>	45 degrees
		<b>Width</b>	20 inches
		<b>Height</b>	42 inches
		<b>Depth</b>	18 inches

### What's Included

- WindFall Kiosk Floor Stand
- WindFall Frame for any tablet
- Kensington ClickSafe adapter plate
- Assembly tools
- Assembly hardware

**Available Colors** Additional and custom colors available upon request. Minimum order and additional charges will apply.

