

# 15" TWAtom270 - Fanless Touch Computer

## Mechanical Design

The TWAtom270 is an Intel 945 platform POS PC with a 15" TFTLCD screen and integrated 5-wire resistive touchscreen, designed for professional use in hospitality and specialty retail environments. Intel 945 Motherboard provides a High Performance, Low Power and Fanless design option fulfilling your need. Standard features include Powered RS-232/USB communication ports, resulting into substantial cost saving and design flexibility for POS solutions.

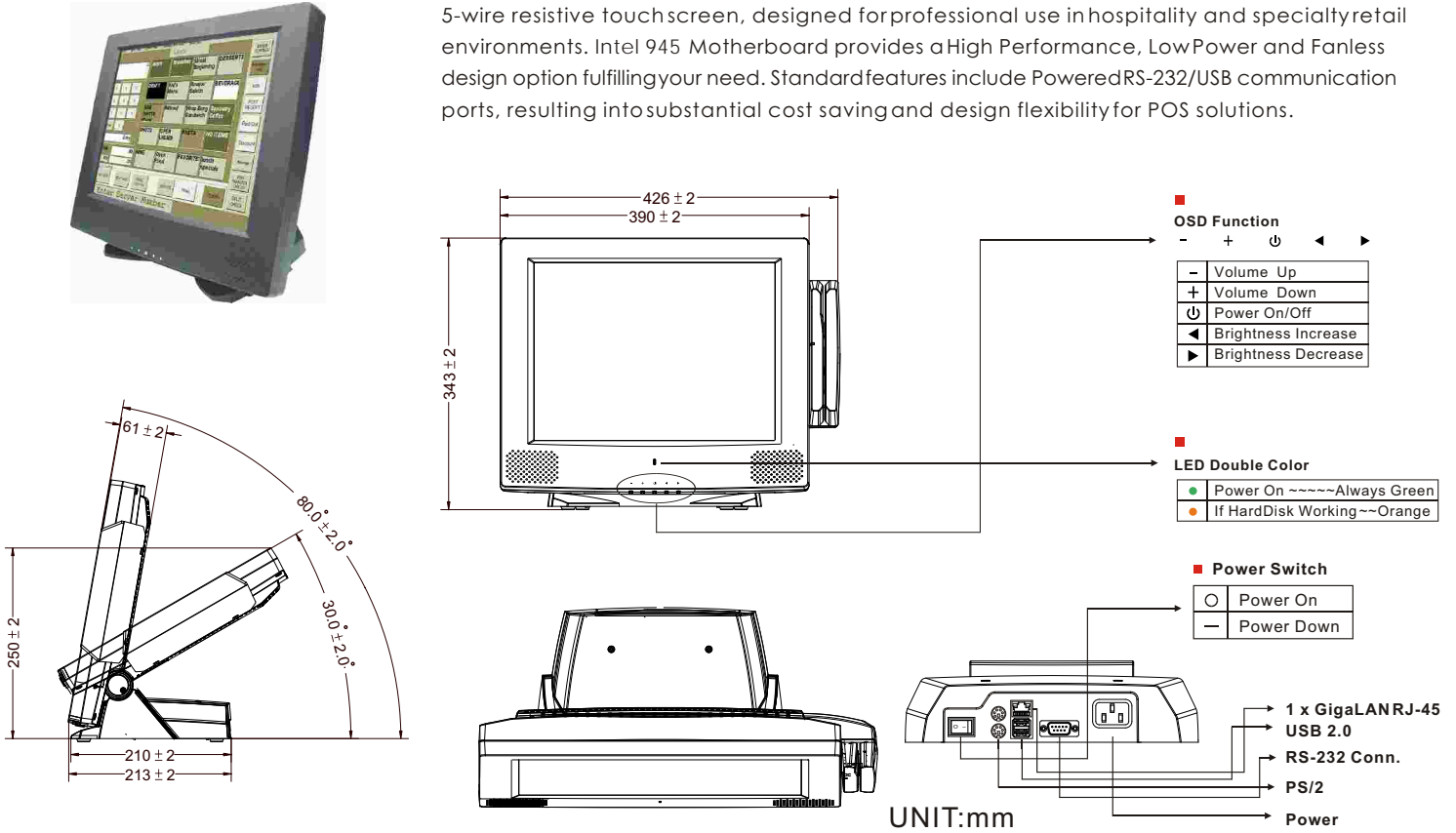

\* Note: this is a simplified drawing and some components are not marked in detail. Please contact our sales representative if you need further product information.

## System Specifications

### TFT Characteristics :

- LCD : 15" LCD Display with Spill Proof
- Touch Screen : 5 Wire Resistive
- Resolutions : 1024 x 768
- Brightness : 250 cd / m<sup>2</sup> (typ.)
- Contrast Ratio : 700 : 1 (typ.)

### Output Connectors :

- Ethernet LAN : 1 x RJ-45 (10/100 Mbps)
- Keyboard / Mouse : 2 x PS/2
- Serial Ports : 1 x RS232 9P D-sub (male)
- USB Interface : 4 x USB 2.0 Ports
- Power Interface : AC-IN Power Receptacle

### System Specification :

- Processor : Intel Atom N270 1.6 GHz
- BIOS : AMI 4Mbit Flash
- System Chipset : Intel 945GSE / ICH7M
- System Memory : 512 MB SODIMM, Max. 2 GB DDR400
- Audio Interface : Realtek Stereo Speakers AC97 codec
- Ethernet : 10/100 Base-T
- Card Reader : Standard Track 1-2-3 (POS-MSR 1-2-3) (Optional)
- Stand : Tilting angle 30 deg.C to 80 deg.C  
Countertop Stand
- OS Support : Windows XP, Windows XP Embedded

### Power & Environment Specifications :

- Power Input : 110V ~ 240V AC IN
- Power Consumption : 60W (typ.)
- Operating Temperature : 0 deg.C to 45 deg.C
- Operating Humidity : 30% ~ 95% (non-condensing)
- EMI / Safety : FCC, CE

### Order Options :

- CPU : AMD Geode LX-800 500MHz Processor
- RAM : 512 MB DDR\*
- Storage : 2.5" 20GB HDD\*
- OS : Windows XPE (optional)

\* Default

Rev.	Reasons	Revised Date
1.0	First release	Apr-03-09

