

REVISIONS				
REV.	DESCRIPTION	CHK	APPD	DATE
A	RELEASE			2/18/11

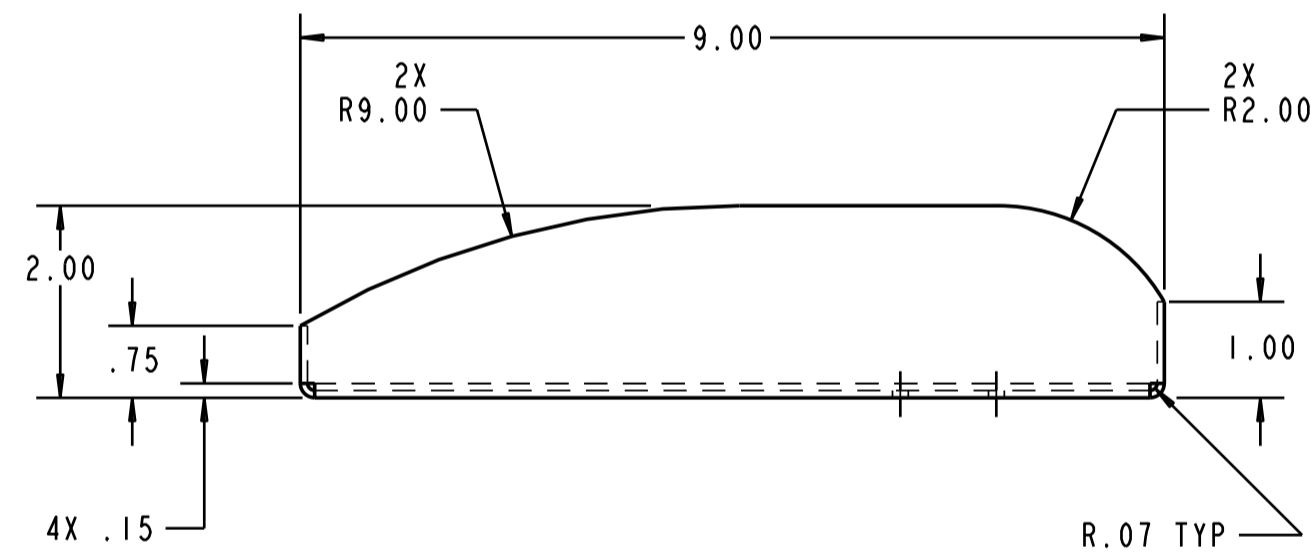

4X WELD SEAM CLOSED AND GRIND SMOOTH TO RADIUS

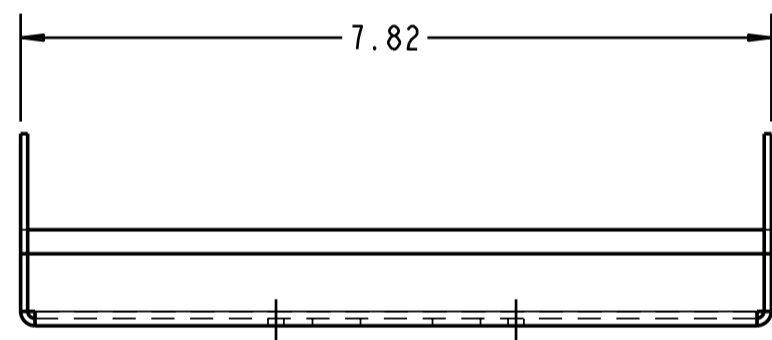
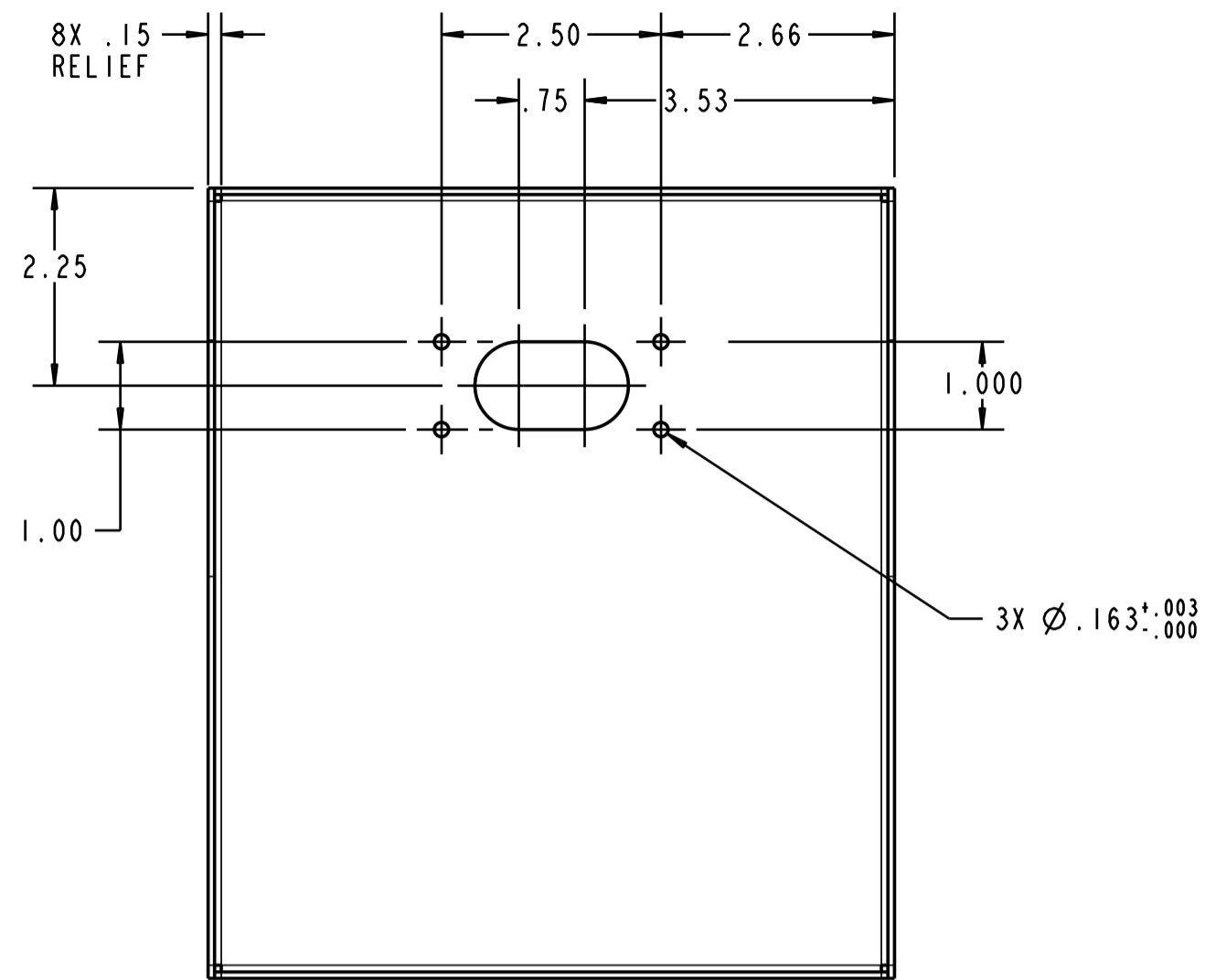
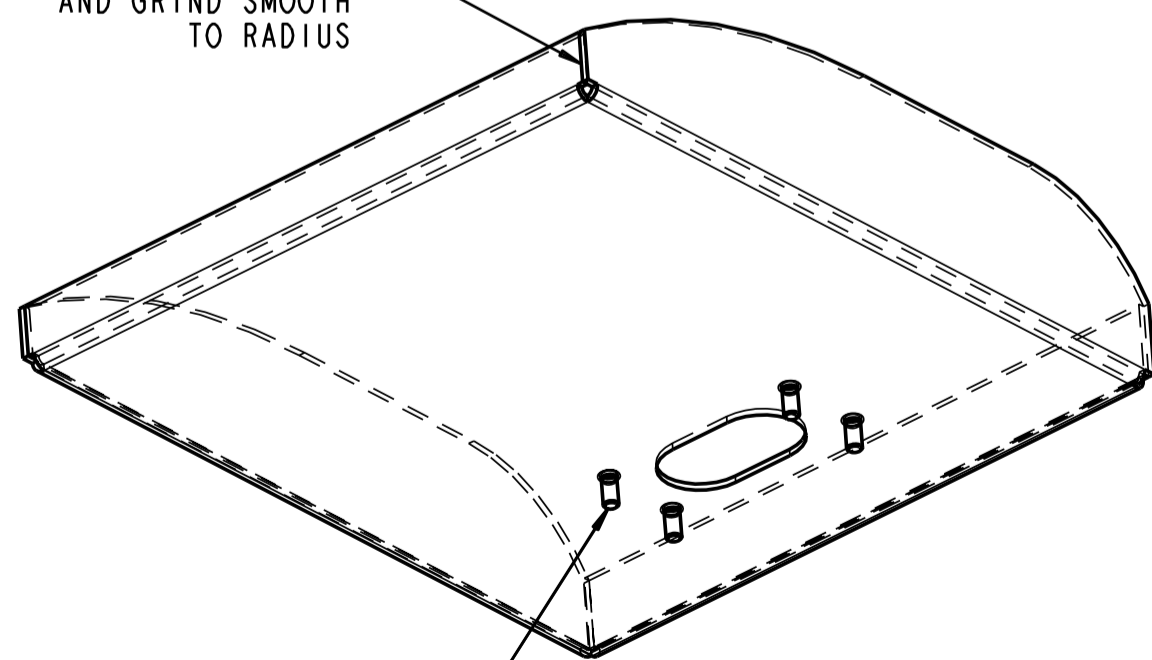

3X PRESS IN PEM STUD
P/N- FH-832-6-Z1
FROM FAR SIDE

NOTES: UNLESS OTHERWISE SPECIFIED

1. MATERIAL: 14 GAUGE (.0747" THK) CRS
2. BREAK SHARP EDGES .015R MAX
3. PRESS IN PENN ENGINEERING FASTENERS AS INDICATED
4. MASK ALL THREADS
5. PRIME AND PAINT: PER PURCHASE ORDER

THIRD ANGLE PROJECTION TOLERANCES: 2 DEC PLCS: ±.015 3 DEC PLCS: ±.005 ANGLES: ±1° DEBURR ALL EDGES	PRODUCT LINE:		TITLE: TRAY, PRINTER (FOR TSP800)	
	DRAWN:	S.K. 2/18/11		
	CHECKED:			
FINISH: SEE NOTE 5	APPROVED:		REV: B	
MATL: SEE NOTE 1	ISSUED:		C	SCALE: 1/2 SHEET 1 OF 1